



Pumps and more



Table of Contents

• About us	4
• WPS	6
• WPS-M	12
• PS-Z	18
• WPZ - 50	24
• WPJ	26
• PHZ	28
• WPCC	30
• SPW-150	32
• WPWE	34
• WPW	40
• WE	46
• WPWH	48
• Engineering company	51
• Repairs	52
• Foundry	54
• Pump units	56

About us



**Zakład Mechaniki Przemysłowej
ZAMEP Sp. z o.o.**

THE ZAMEP INDUSTRIAL MECHANICAL COMPANY LLC



THE ZAMEP INDUSTRIAL MECHANICAL COMPANY LLC was founded in 1994. We mainly design and manufacture centrifugal pumps, single and multi-stage pumps and pump units.

Our pumps are distinguished by the highest possible efficiency with the best lifetime and minimal maintenance. The majority of pumps is selected according to the specified parameters of the Client, gladly supported by our engineering department.

We have specialized machine park and modern foundry which allows to perform the entire production cycle in our factory. This allows us to monitor on a regular basis every stage of production, so we are able to achieve the highest quality and reliability of our pumps.

Materials we use mainly for production are cast iron, cast steel, bronze, duplex, superduplex and any other specified by the customer. Our pumps are widely used in industry, such as: mines dewatering up to 1400m, desalination systems, water supply system, general industry, metallurgy, heat engineering, central air conditioning systems, power industry, hydro transport, boiler feeding, chemical industry, and other.



MEDIUM PRESSURE IMPELLER PUMP

Type BB4

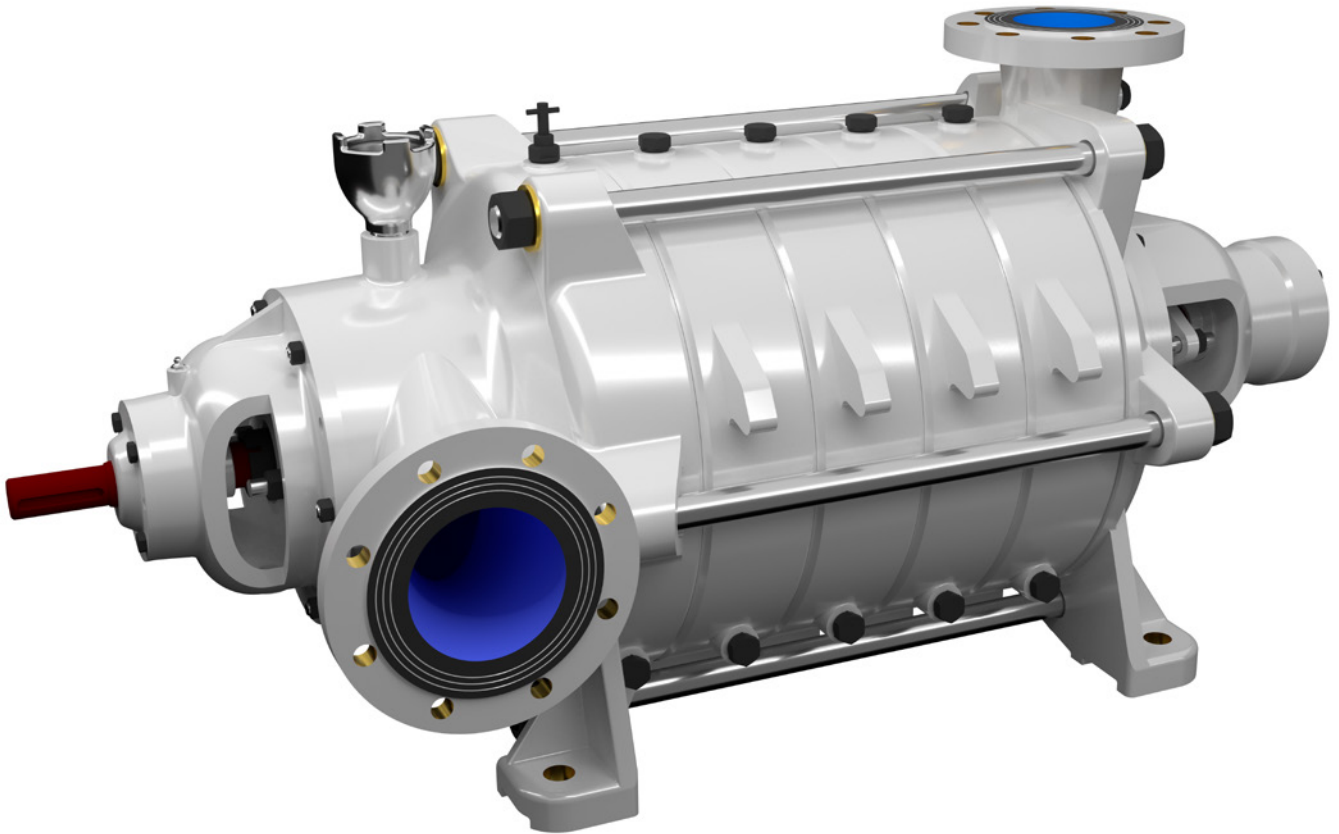

TYPICAL APPLICATIONS

- pumping of pure or mechanically contaminated water with solids with the grain size of up to 2mm (5/64 inch),
- mining – longwall and auxiliary dewatering WPS pumps intended to replace existing medium pressure drainage pumps,
- water supply systems,
- pressure boosting,
- technological processes,
- industrial systems.

KEY ADVANTAGES

- long life ensured by the use of state-of-the-art corrosion and erosion resistant materials,
- no water cooling of bearings required due to the appropriate design of the relief of the pump axial forces,
- silent and smooth operation,
- connection dimensions in compliance with medium pressure drainage pumps,
- inflow and suction operation,
- compact and modern design,
- maintenance-free operation with the use of mechanical sealing,
- approved for operation in explosion-hazard zones – ATEX Ex I M2.

PUMP PERFORMANCE CURVE

WPS-80

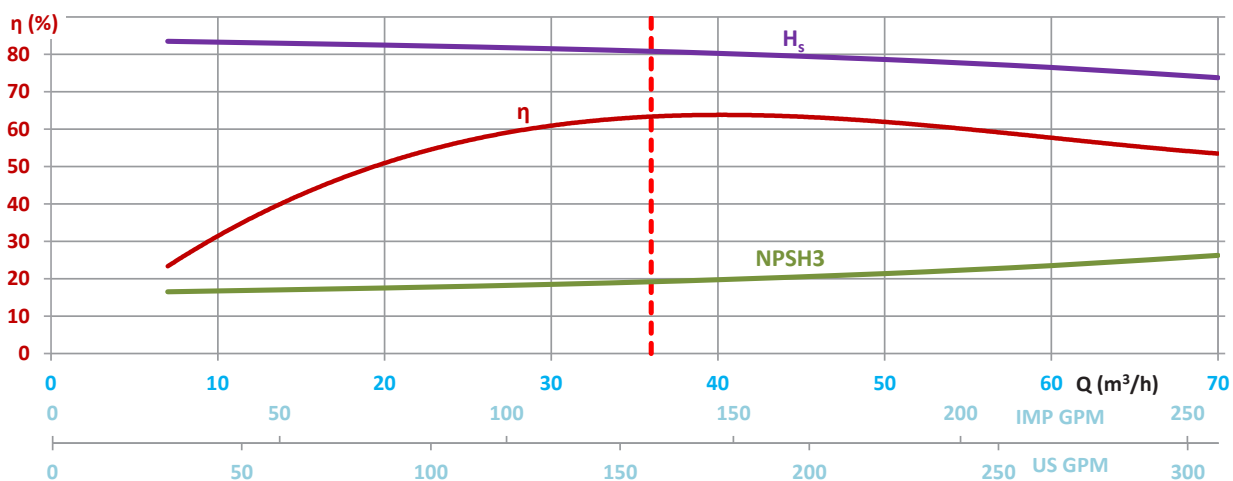
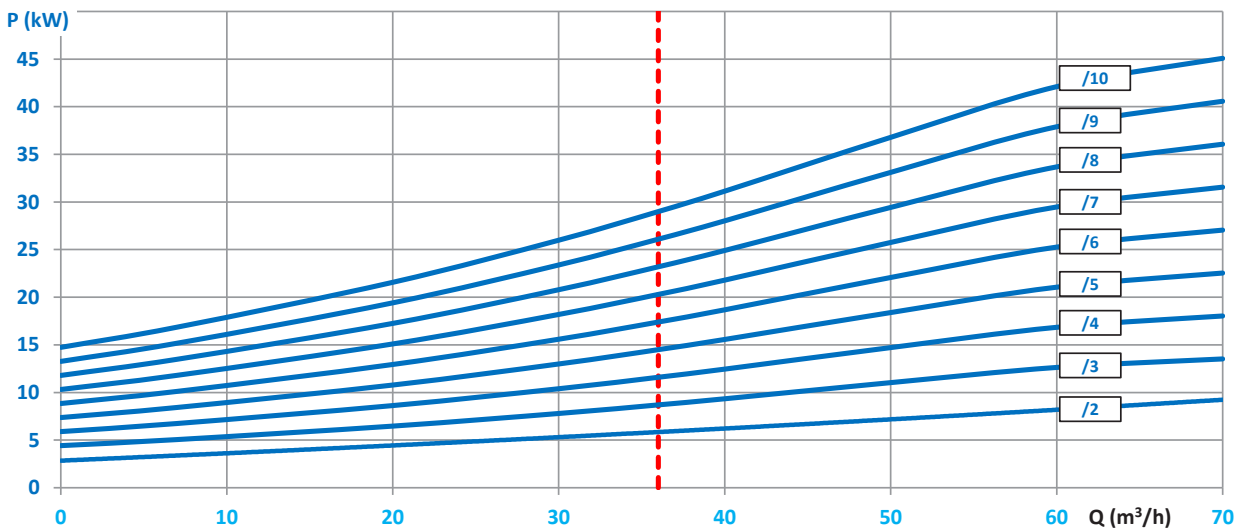
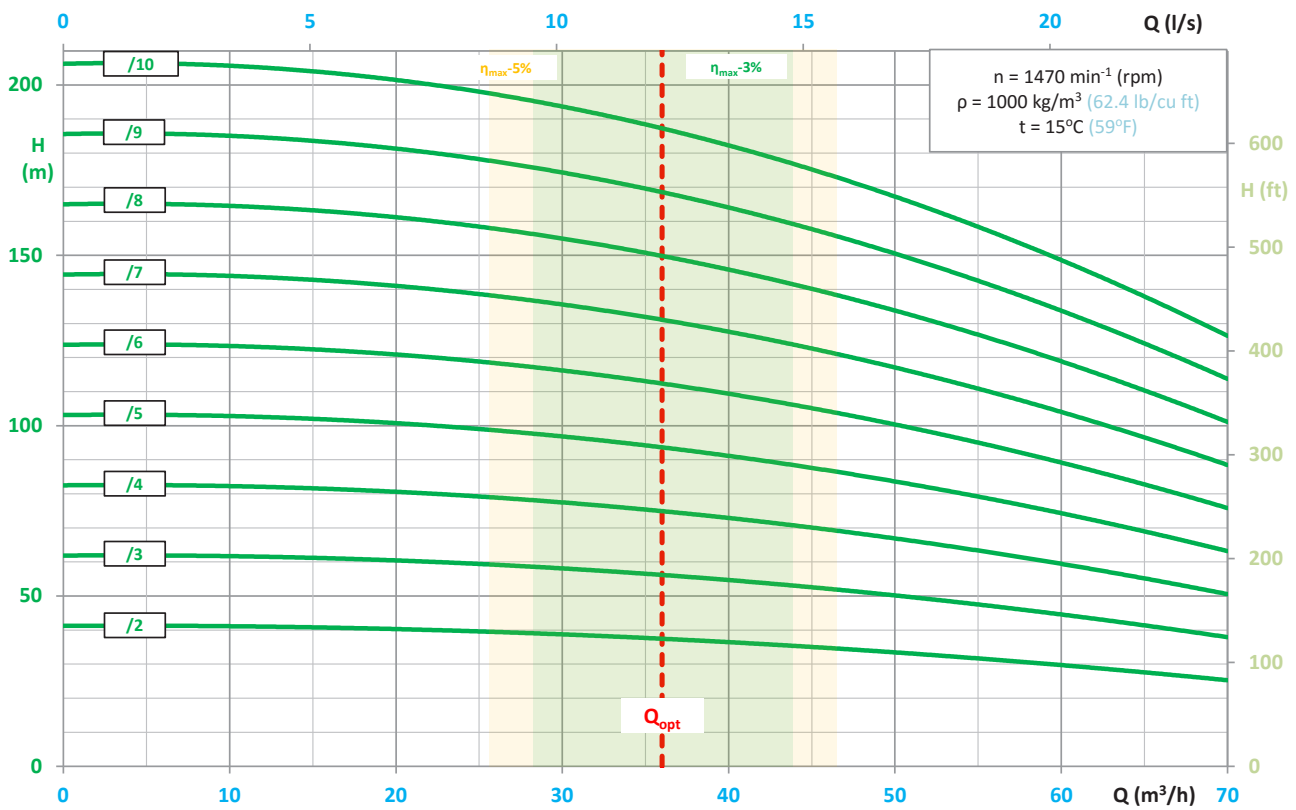

H_s , NPSH3	(m)	(ft)
8	26.2	
7	23.0	
6	19.7	
5	16.4	
4	13.1	
3	9.8	
2	6.6	
1	3.3	
0	0	

X-axis: 0 50 100 150 200 250 300 US GPM
 X-axis: 0 50 100 150 200 250 IMP GPM

WPS-100A

PUMP PERFORMANCE CURVE

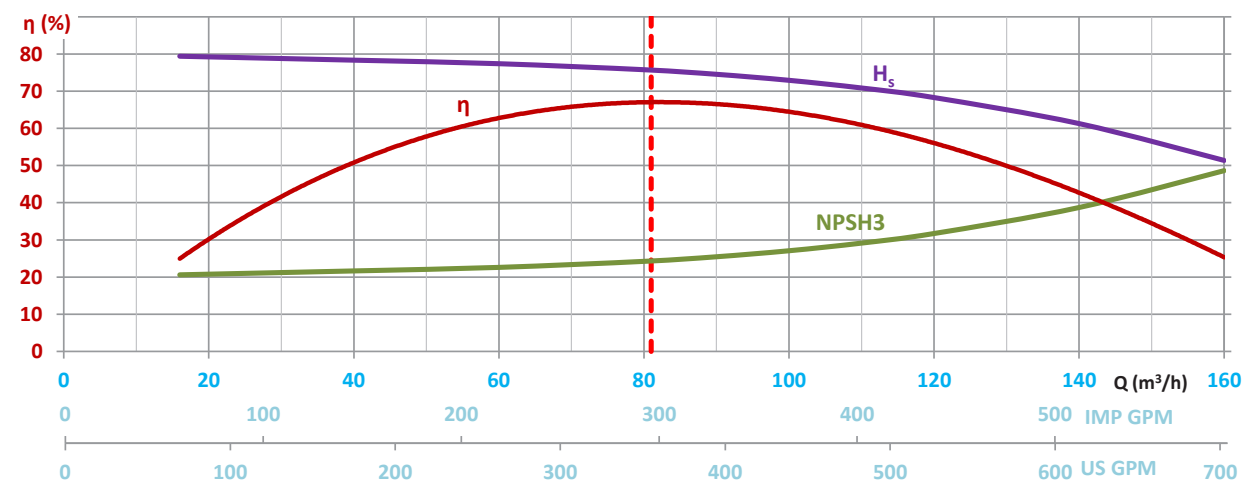
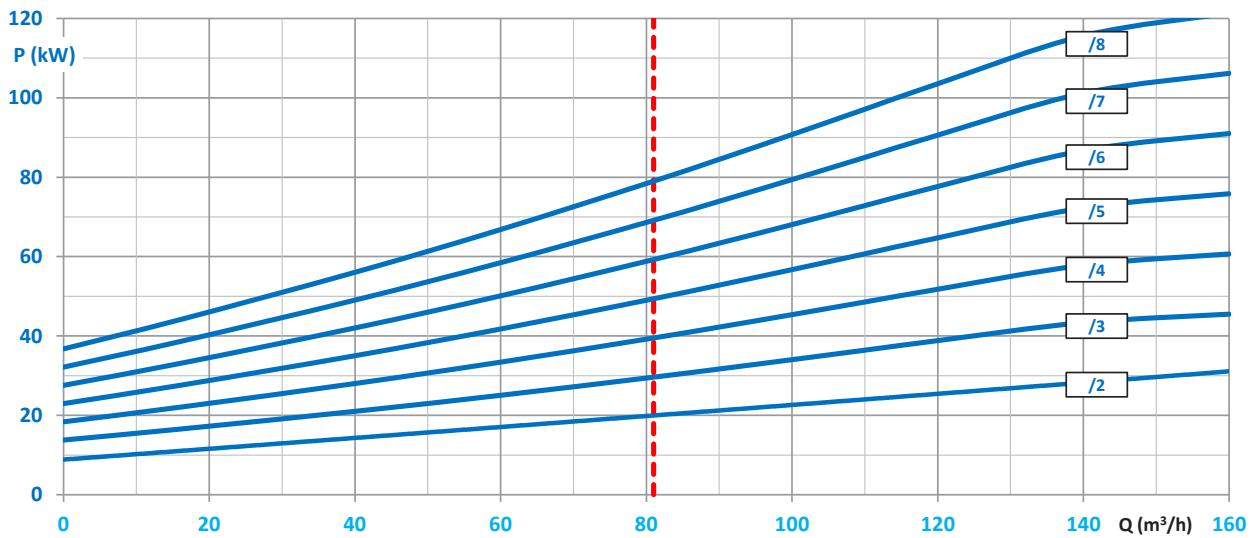
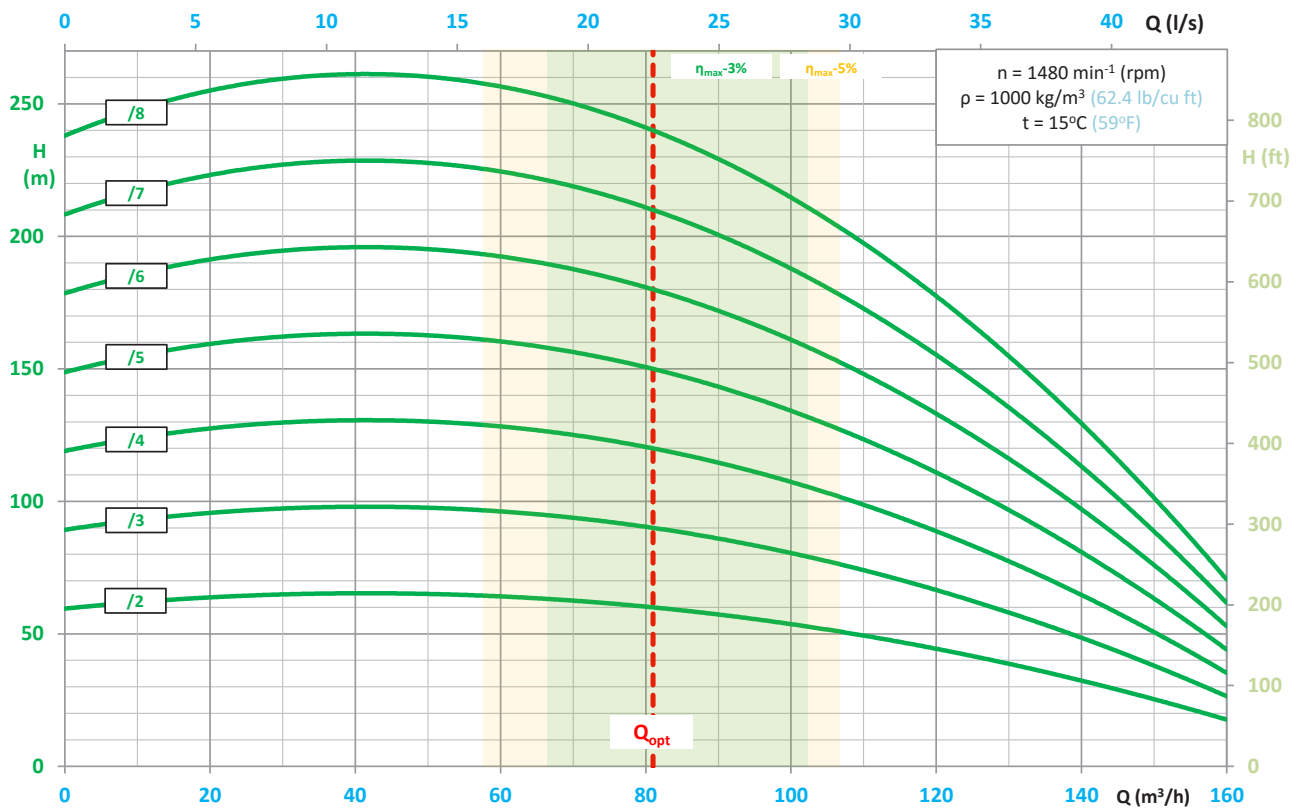

H_s , NPSH3	(m)	(ft)
8	26.2	
7	23.0	
6	19.7	
5	16.4	
4	13.1	
3	9.8	
2	6.6	
1	3.3	
0	0	

PUMP PERFORMANCE CURVE

WPS-100

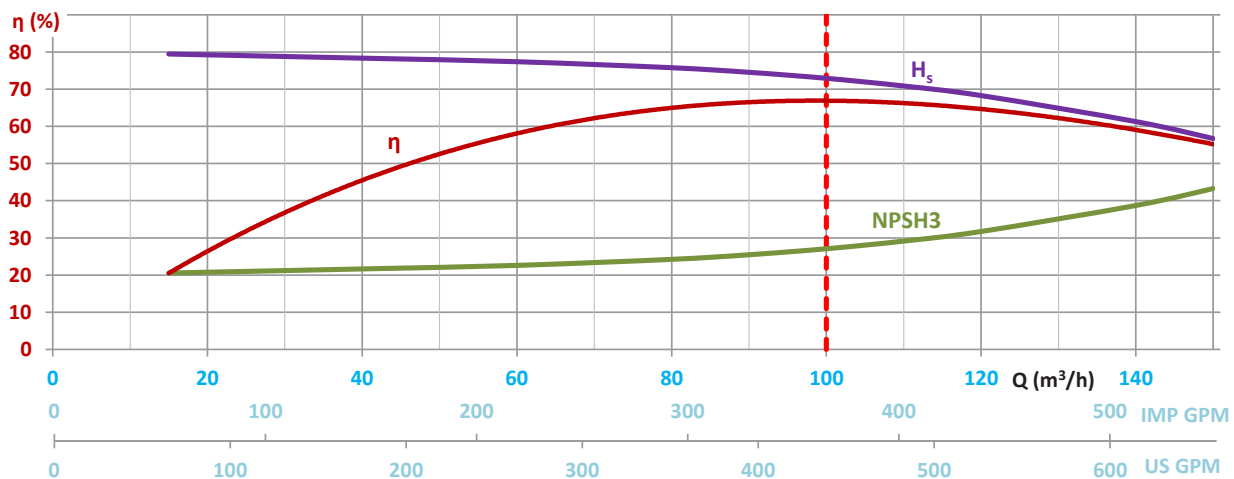
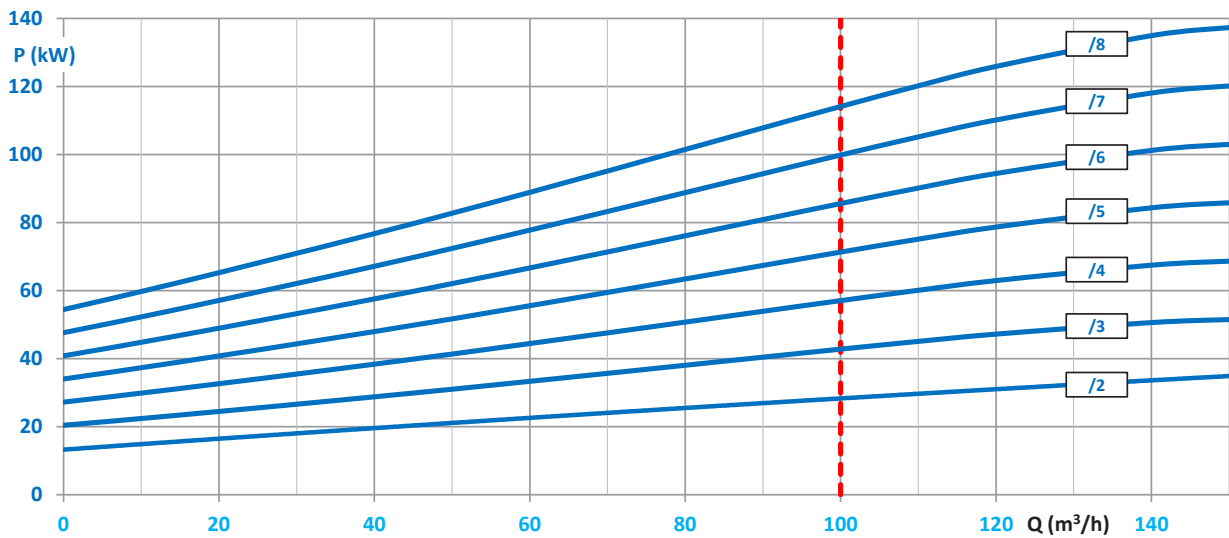
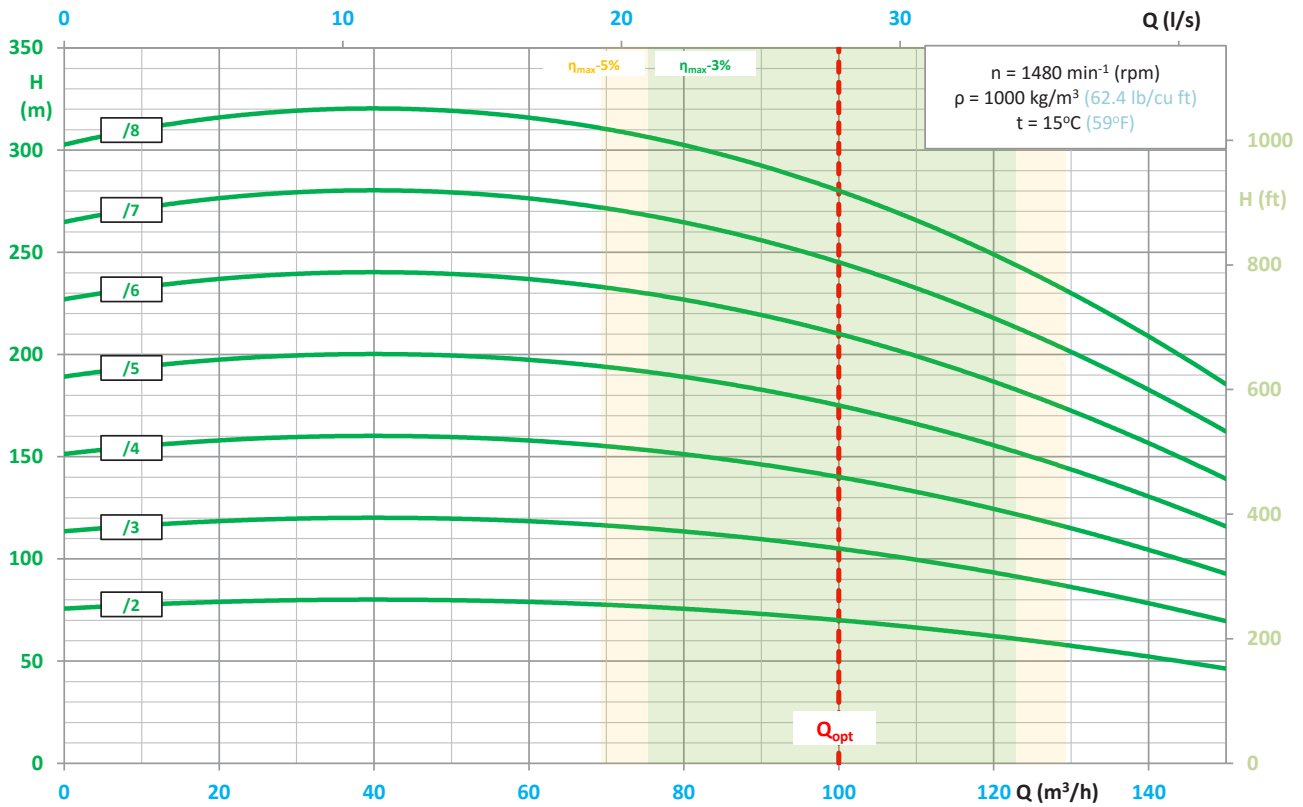

H_s , NPSH3 (m) (ft)	Impeller Diameter (in)
8 26.2	8
7 23.0	7
6 19.7	6
5 16.4	5
4 13.1	4
3 9.8	3
2 6.6	2
1 3.3	1
0 0	0

WPS-150

PUMP PERFORMANCE CURVE

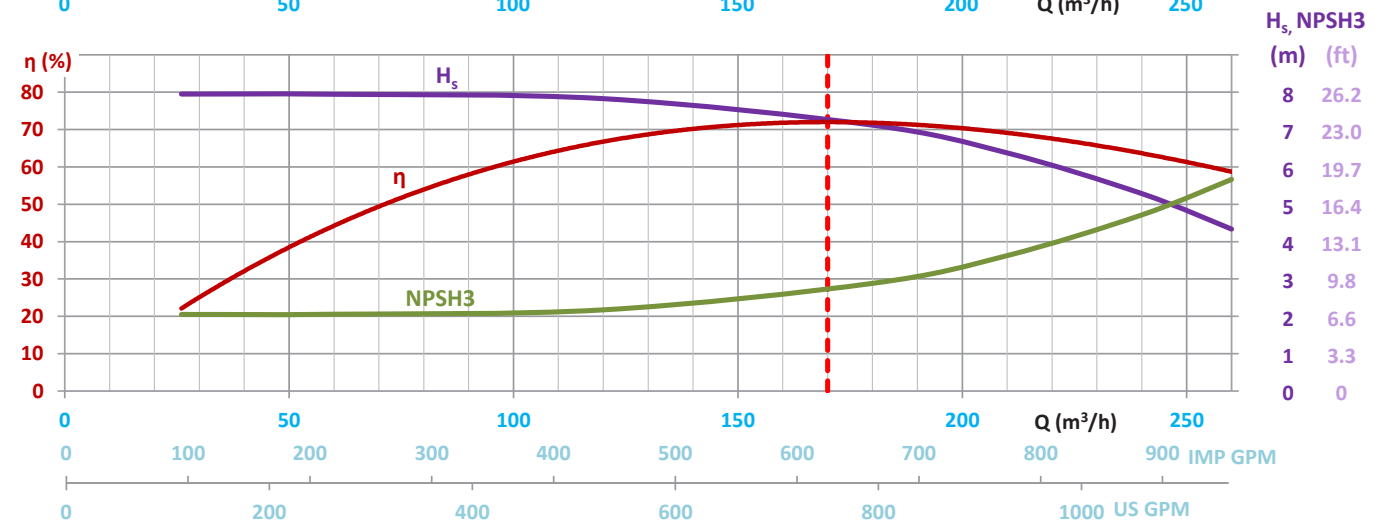
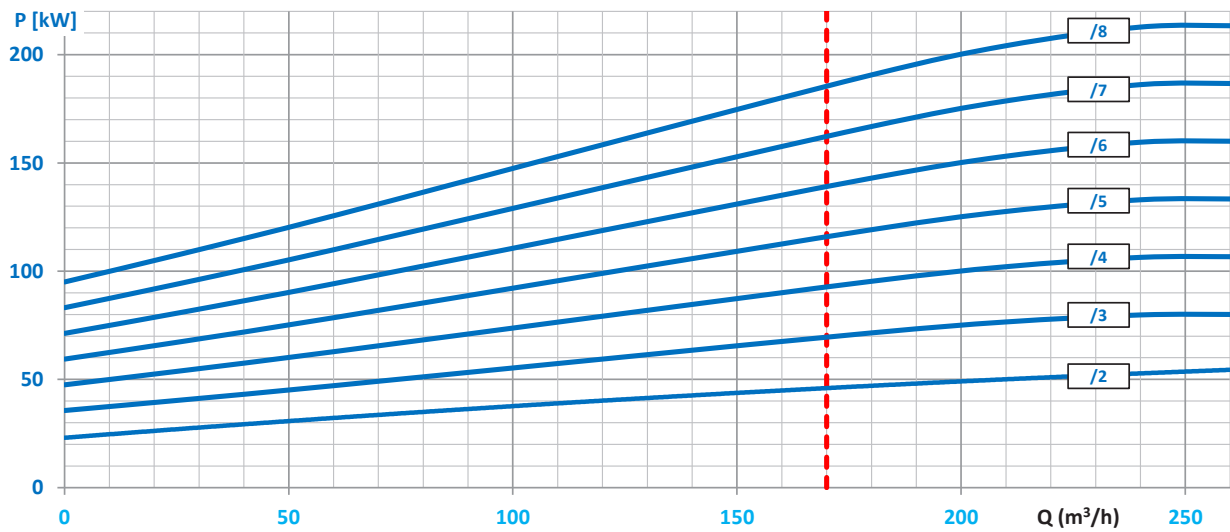
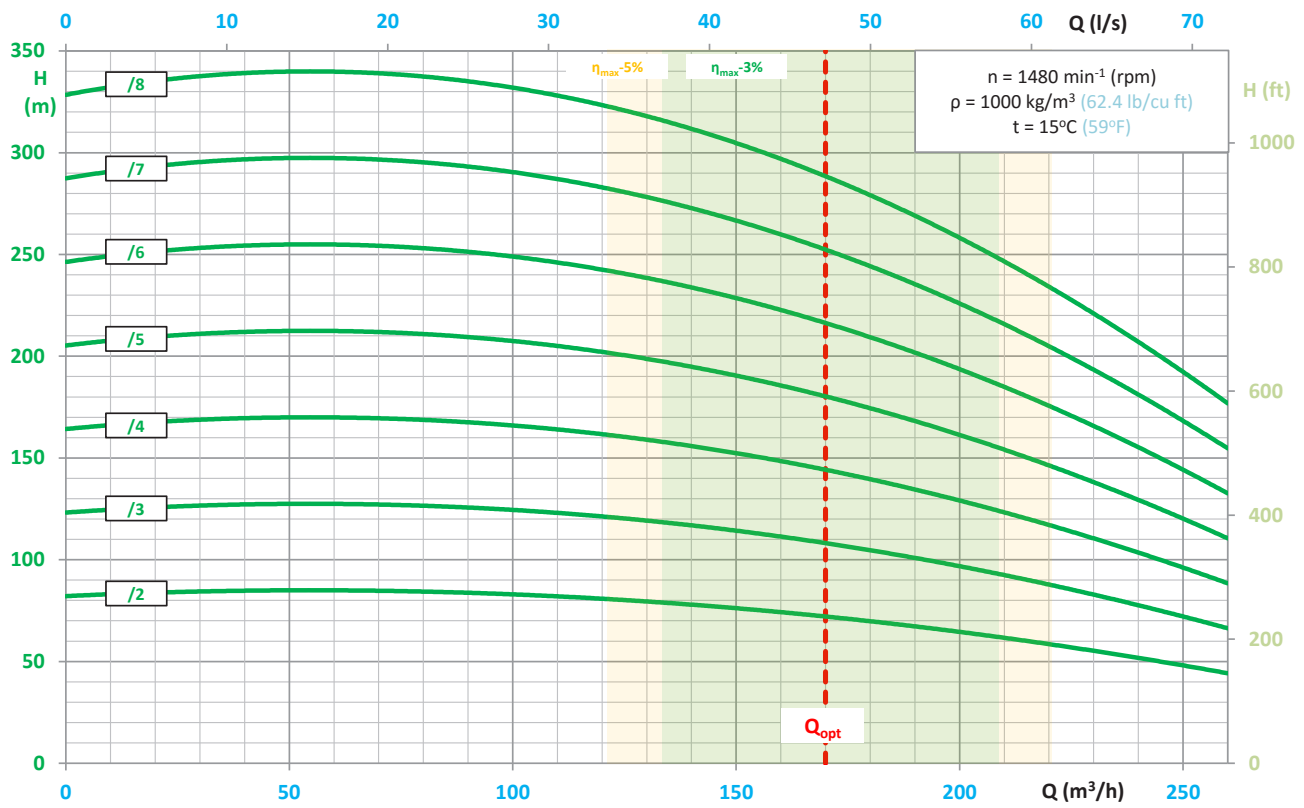

PUMP PERFORMANCE CURVE

WPS-200

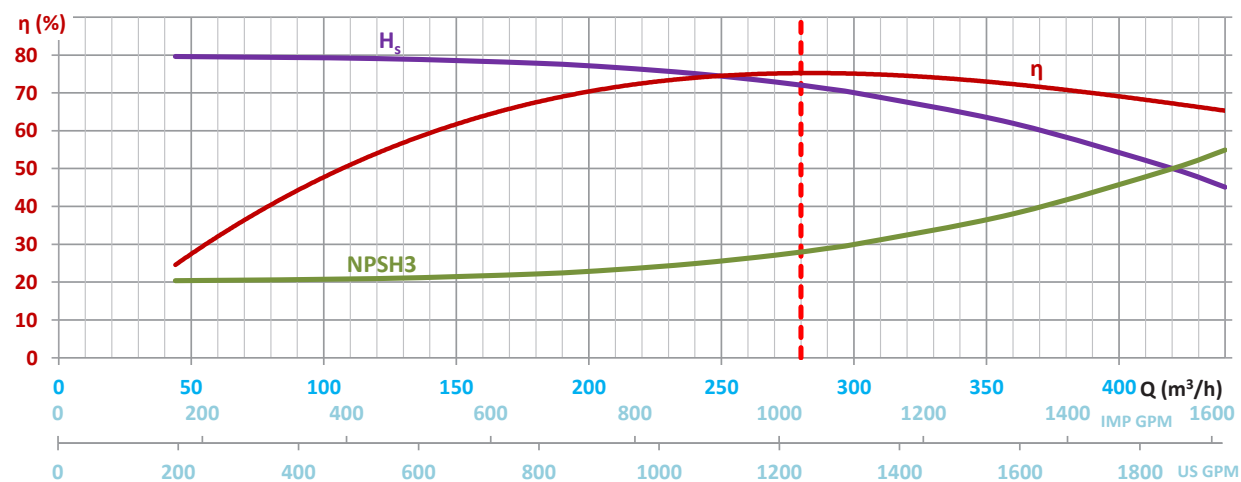
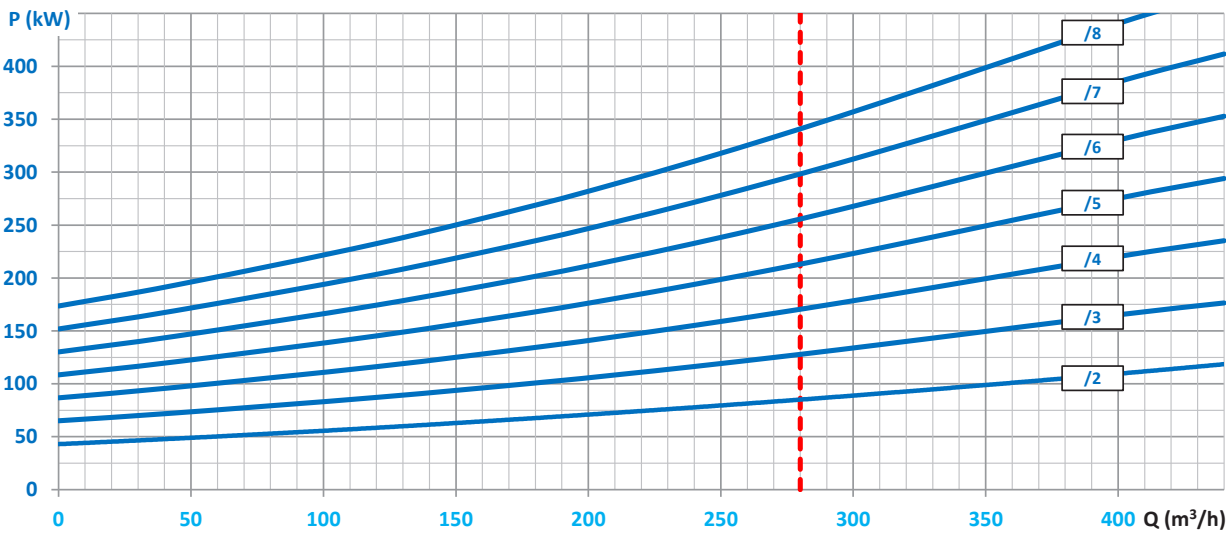
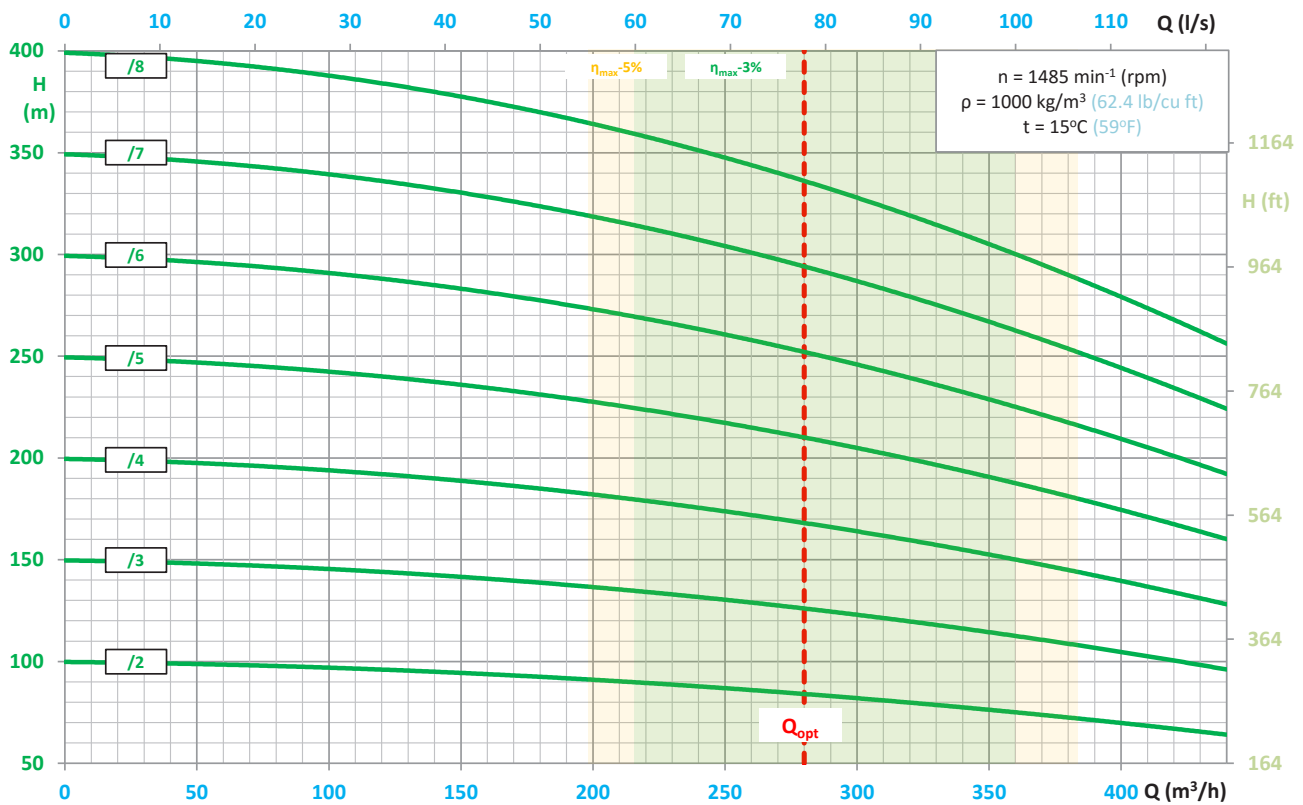

MEDIUM PRESSURE IMPELLER PUMP

Type BB4

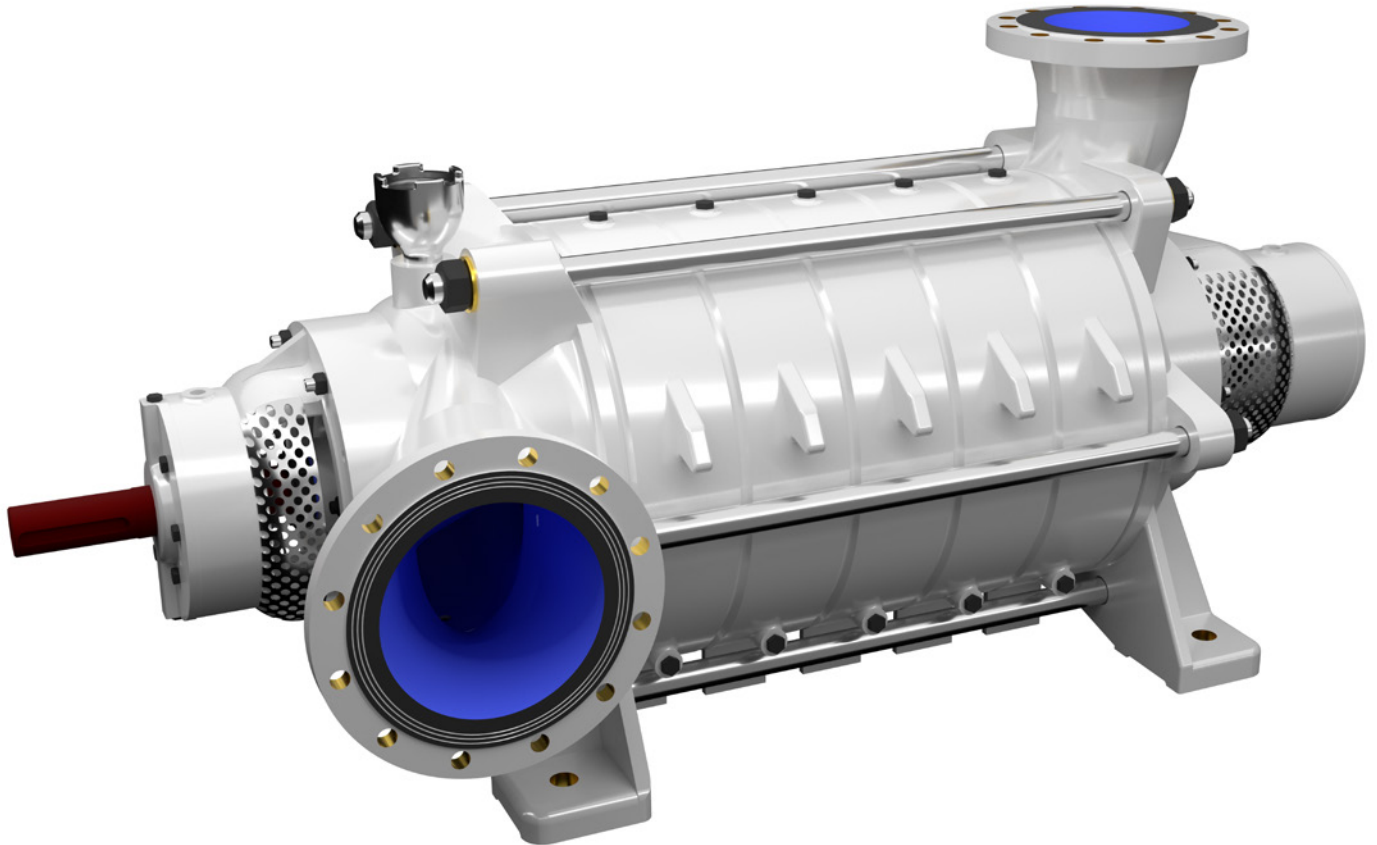

TYPICAL APPLICATIONS

- pumping of pure or mechanically contaminated water with solids with the grain size of up to 2mm (5/64 inch),
- mining – longwall and auxiliary dewatering WPS-M pumps intended to replace existing medium pressure drainage pumps,
- water supply systems,
- pressure boosting,
- technological processes,
- industrial systems.

KEY ADVANTAGES

- long life ensured by the use of state-of-the-art corrosion and erosion resistant materials,
- no water cooling of bearings required due to the appropriate design of the relief of the pump axial forces,
- silent and smooth operation,
- connection dimensions in compliance with medium pressure drainage pumps,
- inflow and suction operation,
- compact and modern design,
- maintenance-free operation with the use of mechanical sealing,
- approved for operation in explosion-hazard zones – ATEX Ex I M2.

PUMP PERFORMANCE CURVE

WPS-100M

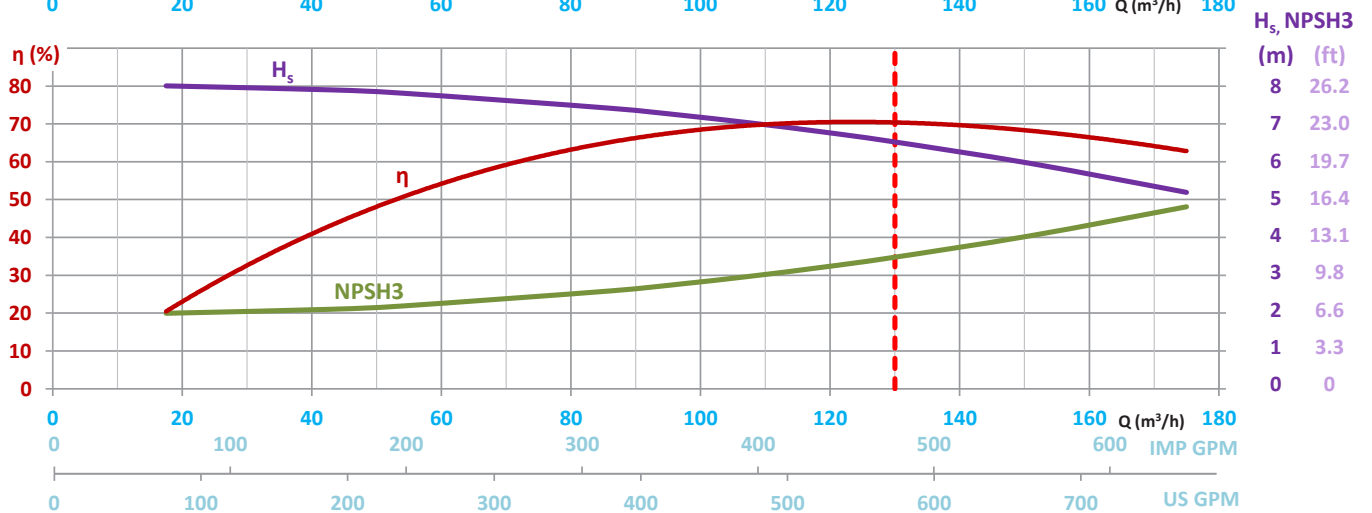
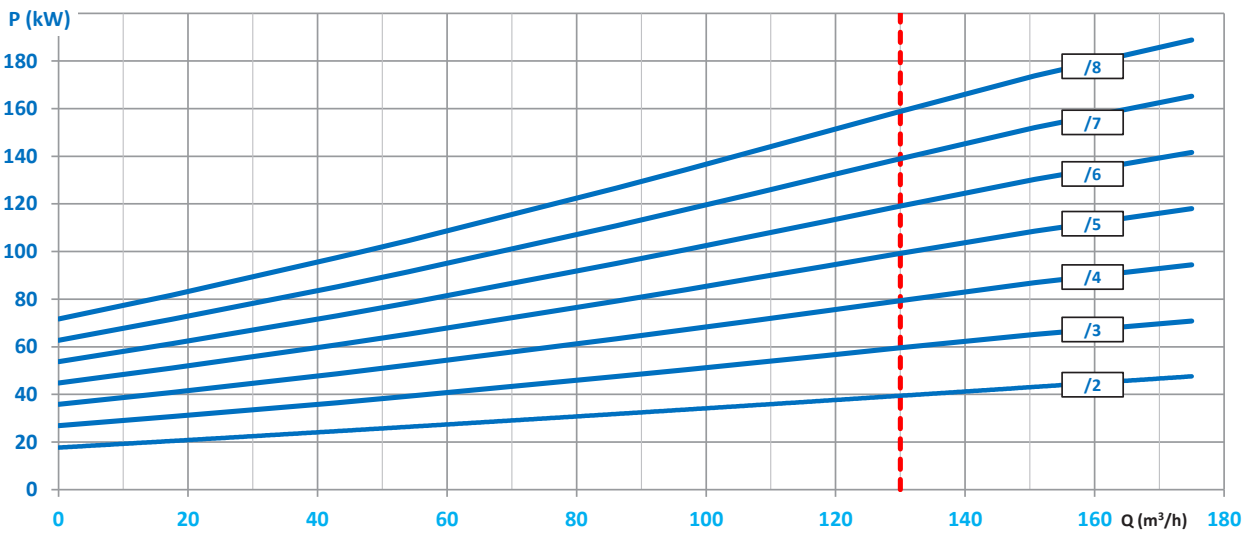
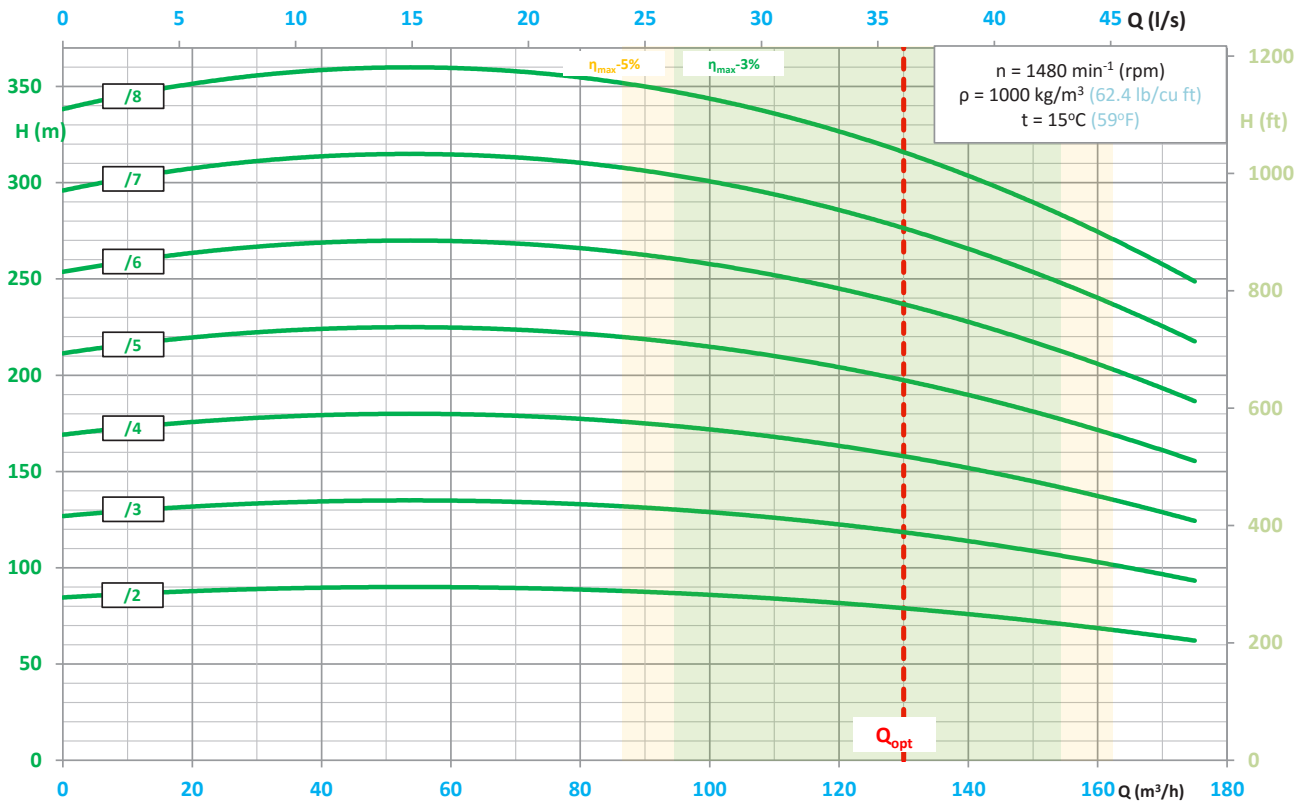

H_s , NPSH3 (m)	(ft)
8	26.2
7	23.0
6	19.7
5	16.4
4	13.1
3	9.8
2	6.6
1	3.3
0	0

WPS-150M

PUMP PERFORMANCE CURVE

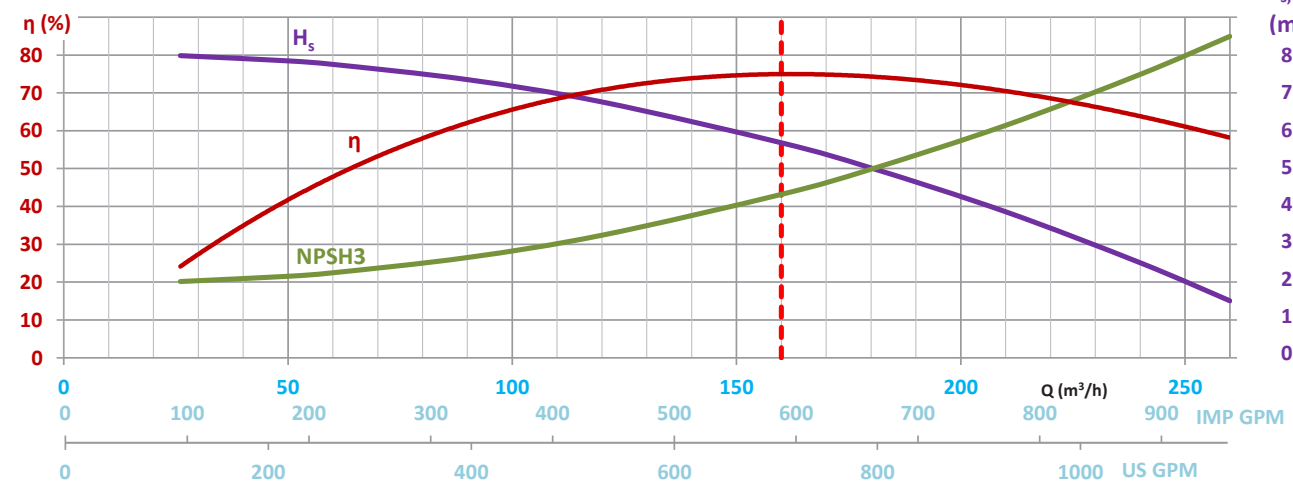
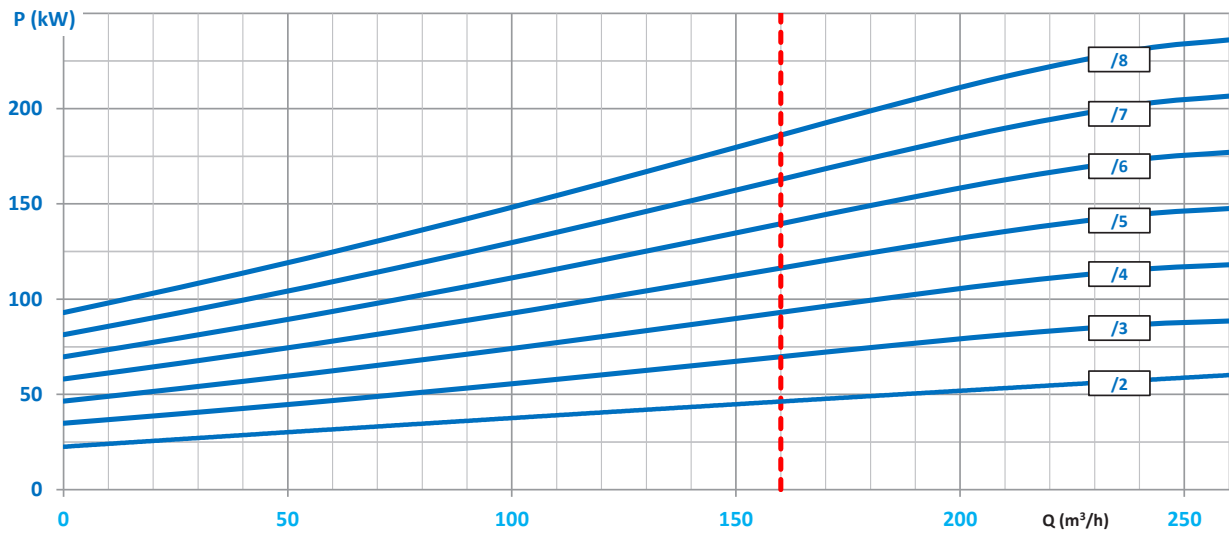
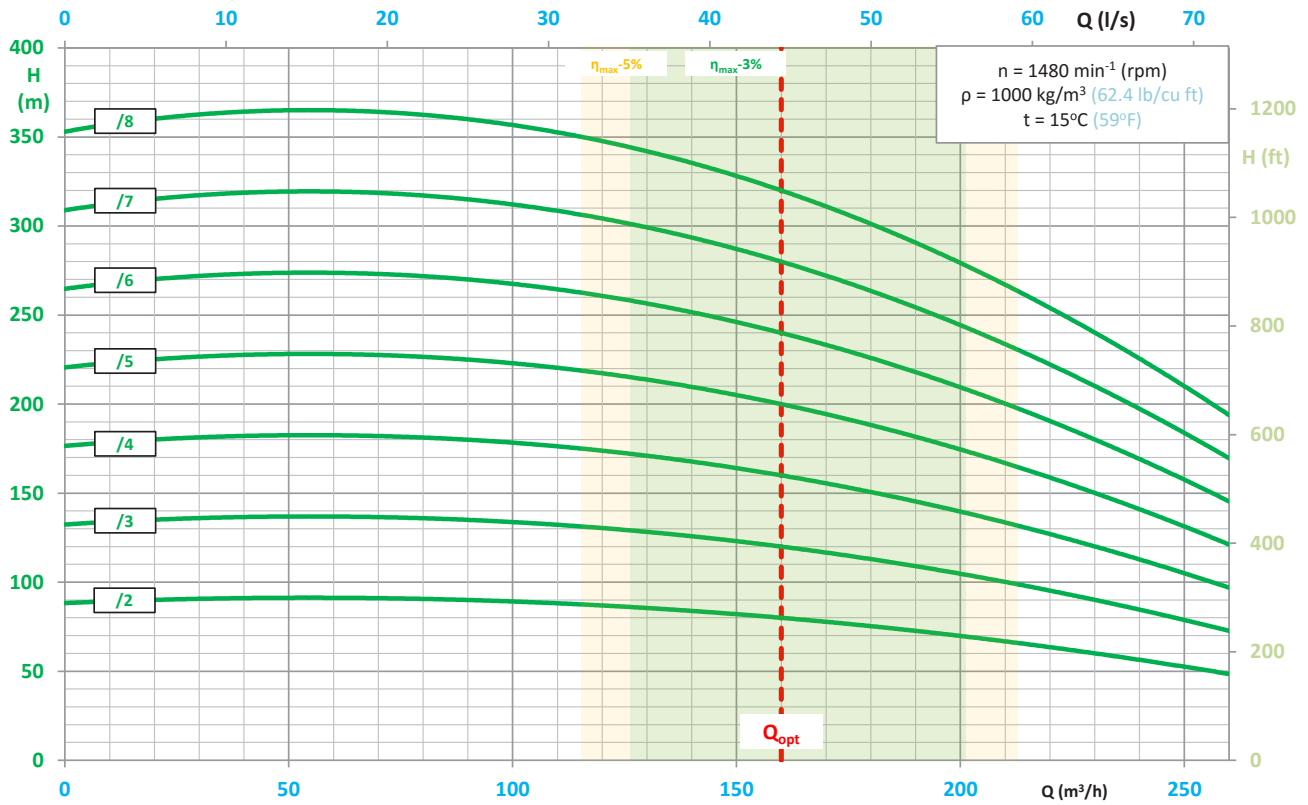

PUMP PERFORMANCE CURVE

WPS-200M

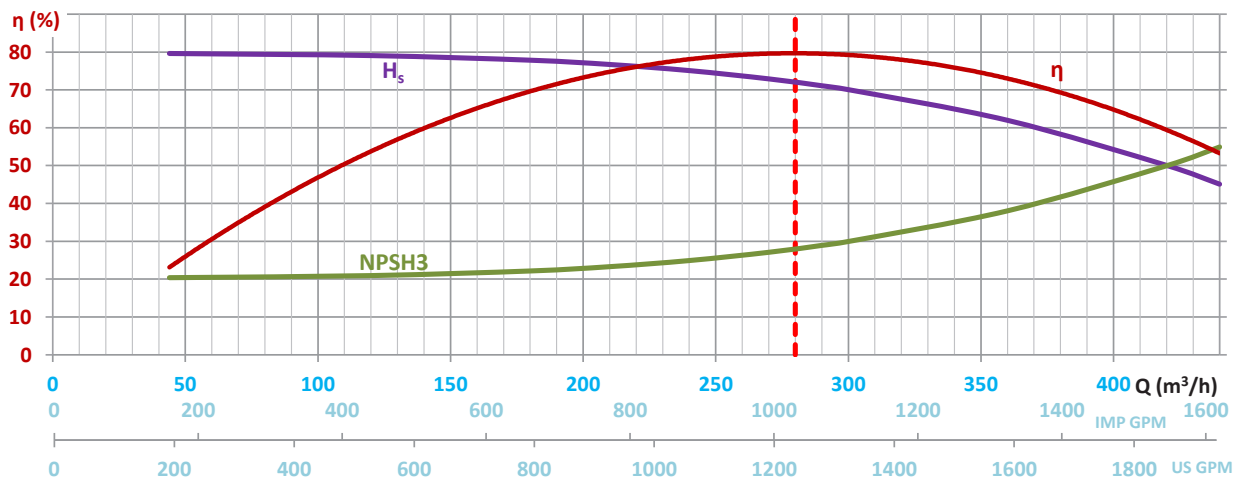
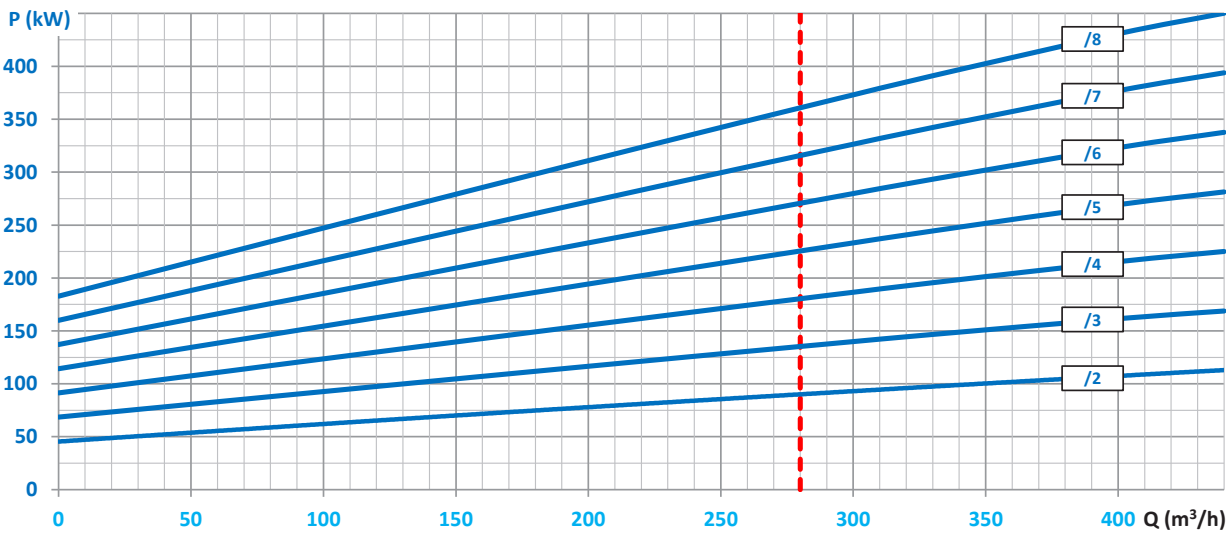
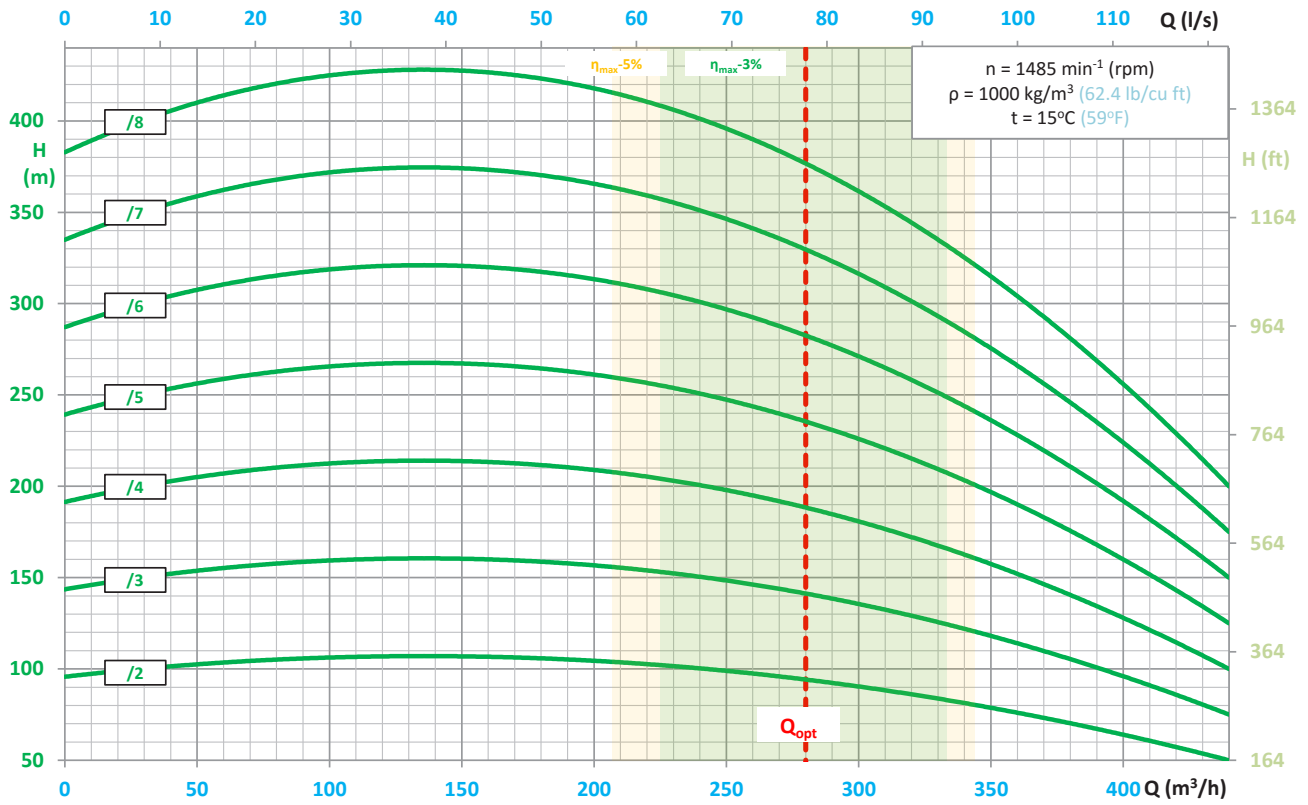

H_s , NPSH3	(m)	(ft)
8	26.2	86.6
7	23.0	75.4
6	19.7	64.6
5	16.4	53.8
4	13.1	42.9
3	9.8	32.1
2	6.6	21.6
1	3.3	10.8
0	0	0

WPS-250M

PUMP PERFORMANCE CURVE

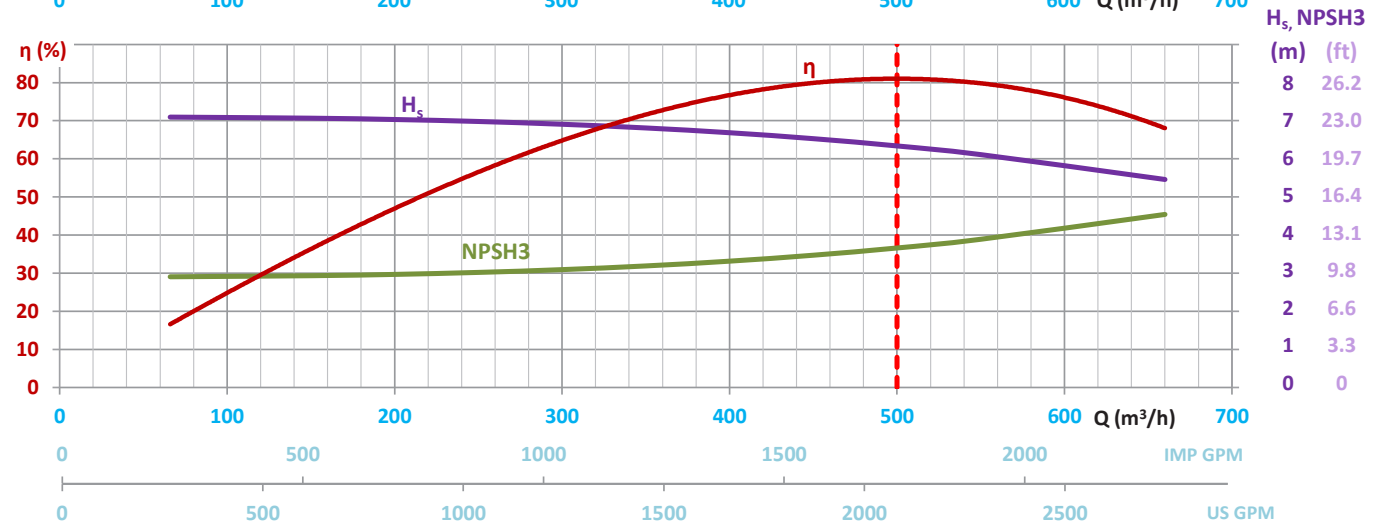
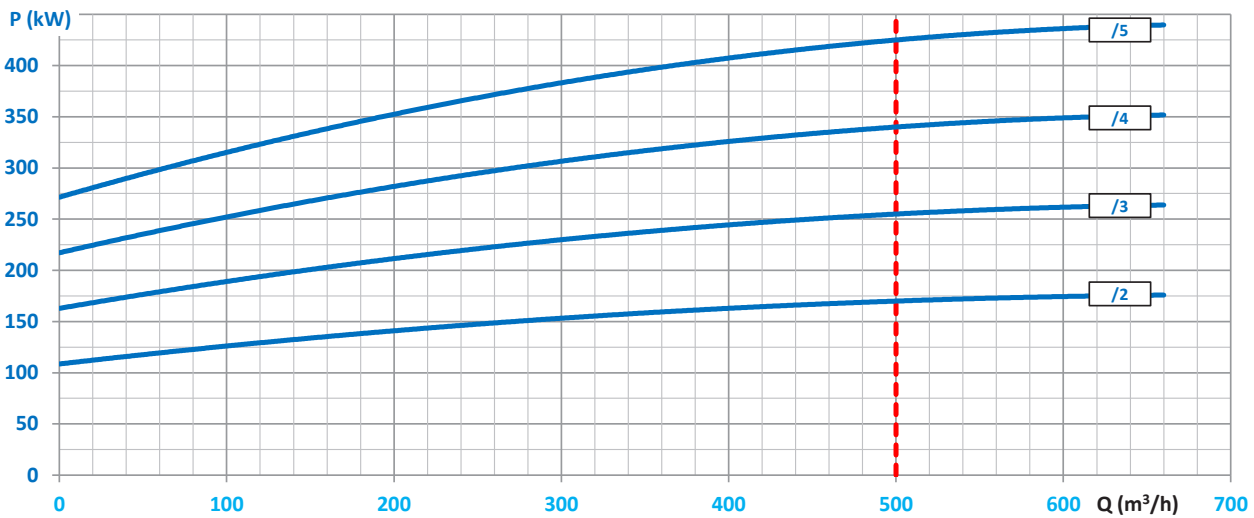
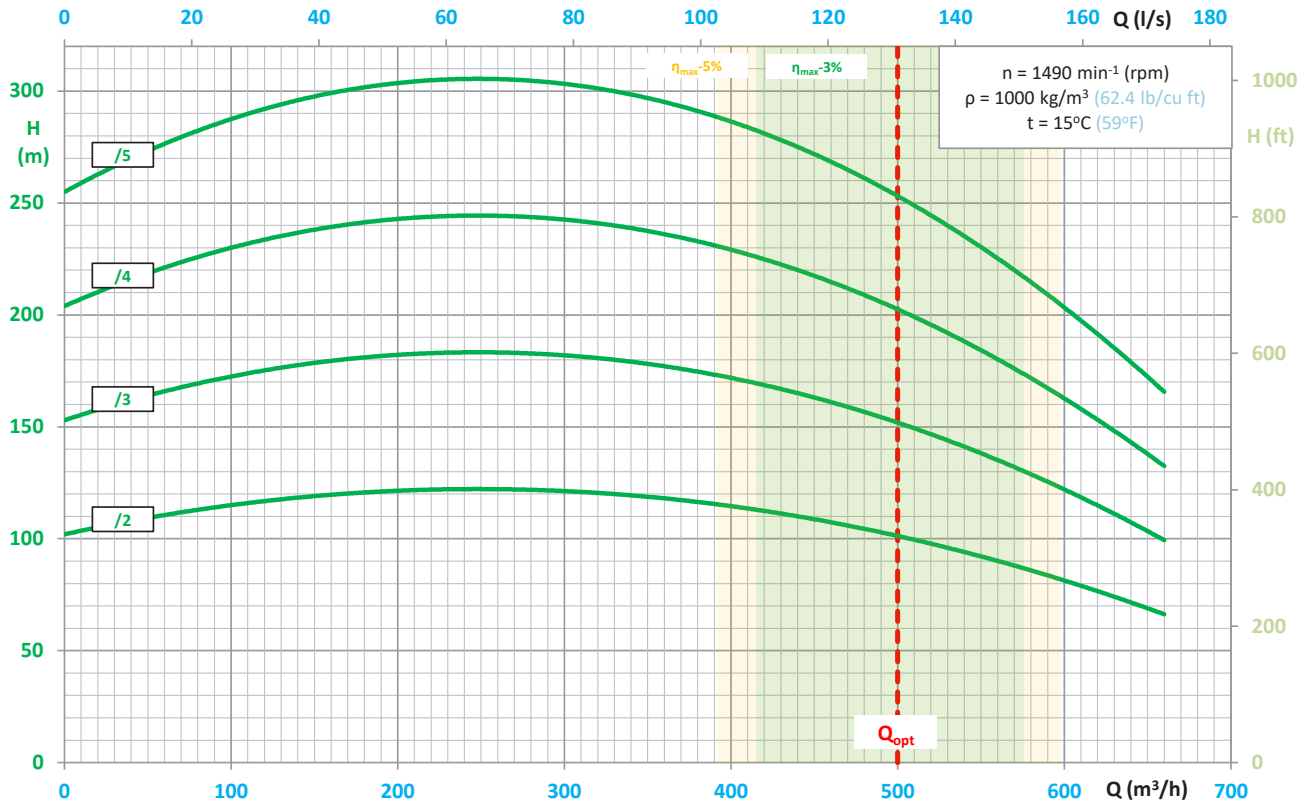

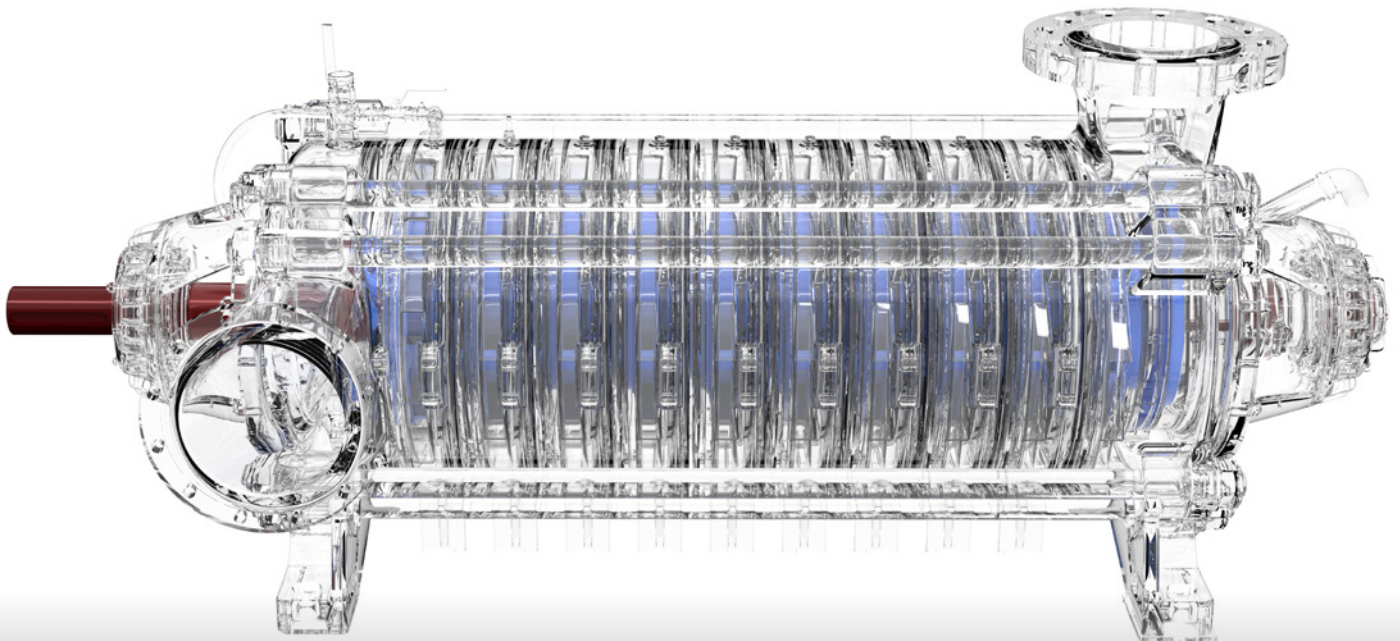
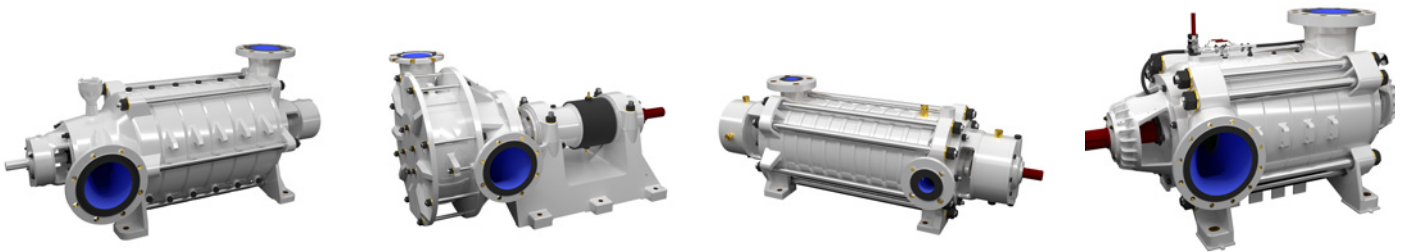
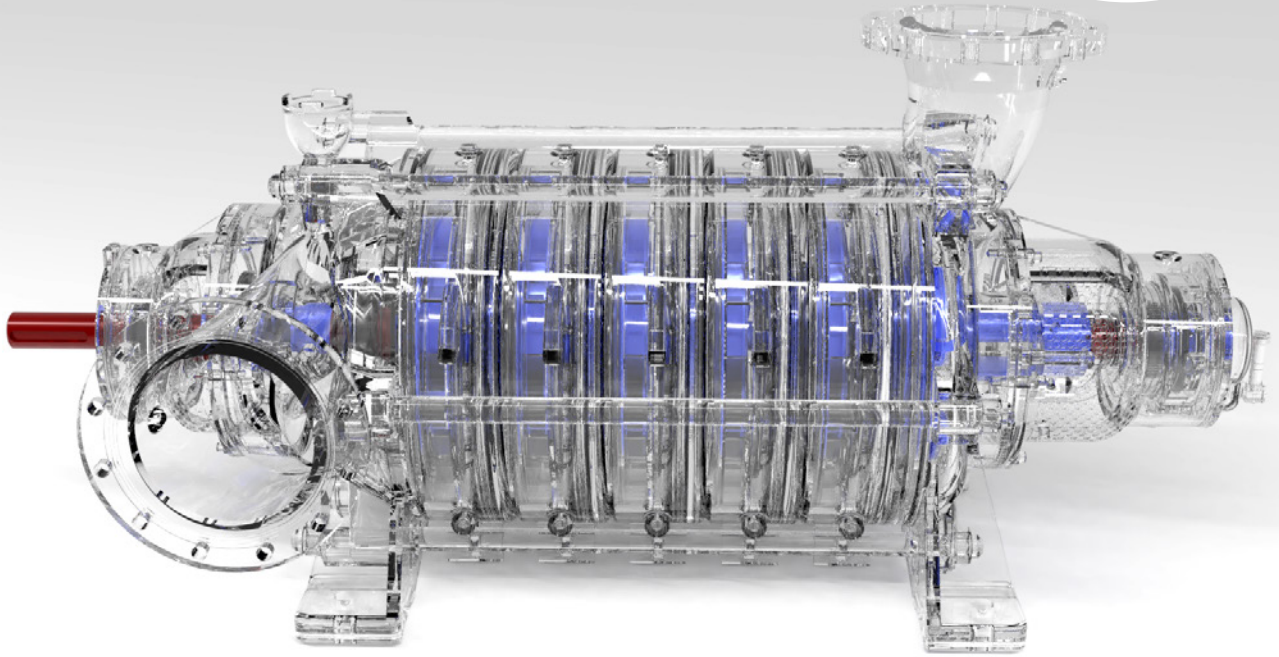

PS-Z

MEDIUM PRESSURE PUMP

Type BB4

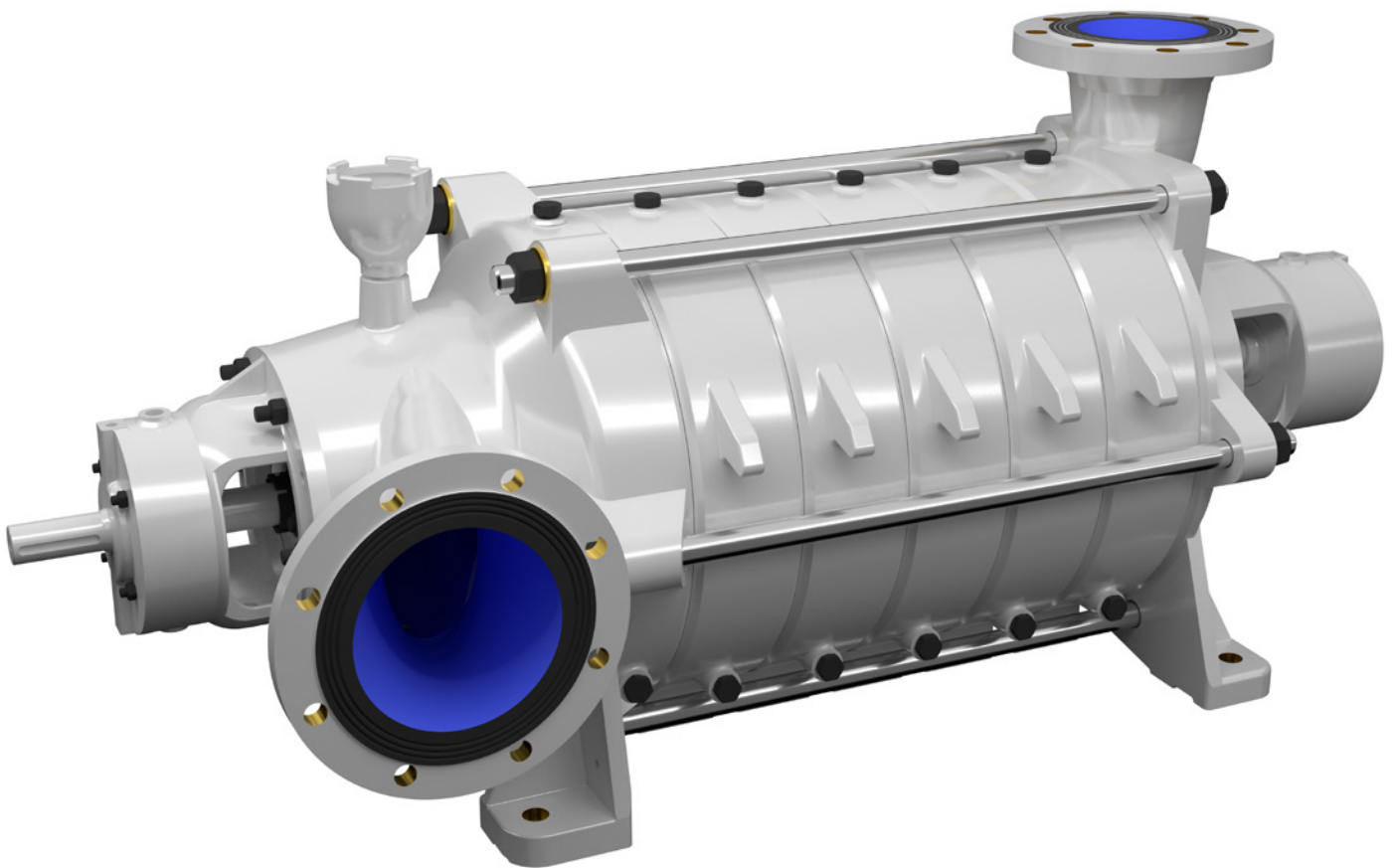

PS-Z medium pressure pumps are intended for pumping pure or mechanically contaminated water with solids with the grain size of up to 2 mm (5/64 inch). In mining they are used for longwall and auxiliary dewatering.

In terms of connection dimensions (spacing of screws fixing the pump to the frame and diameters of the inlet and pumping connector pipes), PS-Z pumps are fully interchangeable with the pumps intended for auxiliary dewatering used so far.

All PS-Z pumps are approved for operation in explosion-hazard zones – ATEX Ex I M2.

For new applications, it is recommended to use a newer design of pumps, i.e. WPS or WPS-M.

PUMP PERFORMANCE CURVE

PS-8oZ

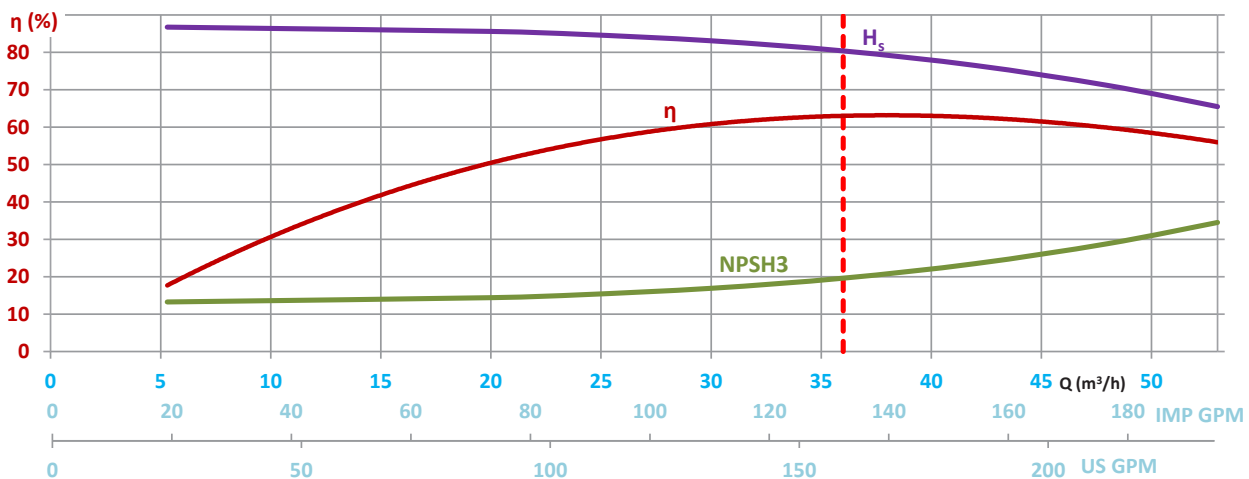
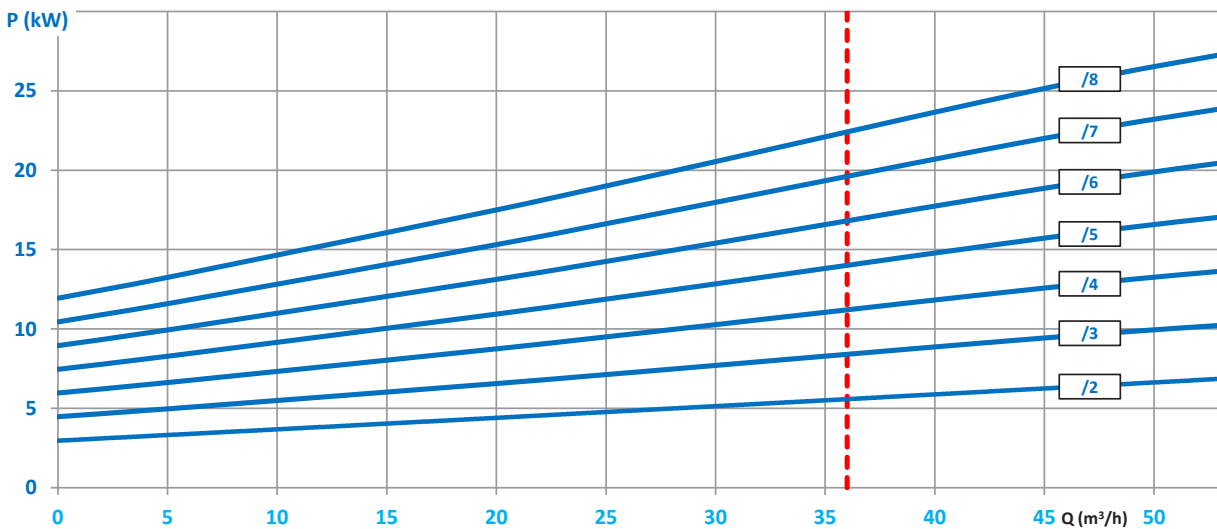
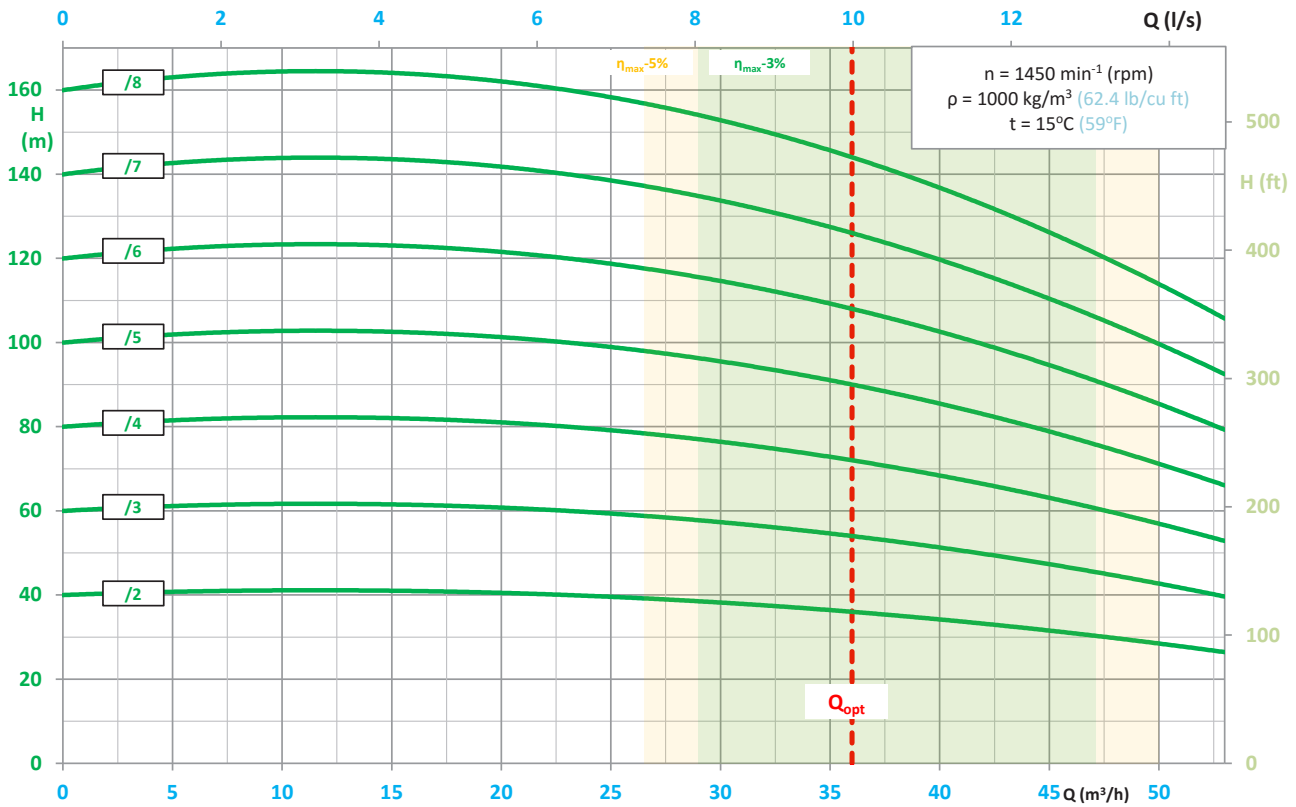

PS-100Z

PUMP PERFORMANCE CURVE

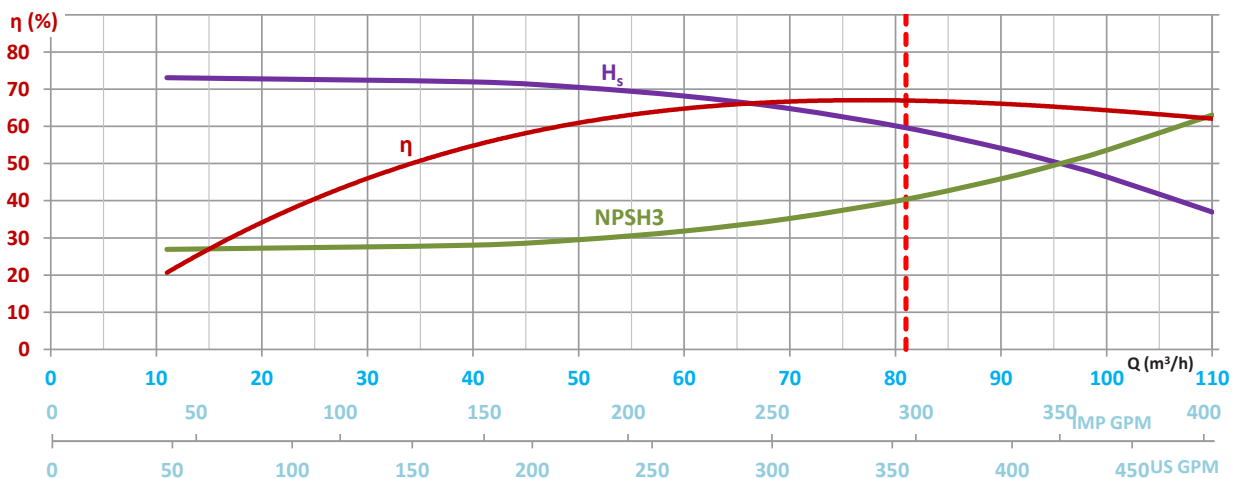
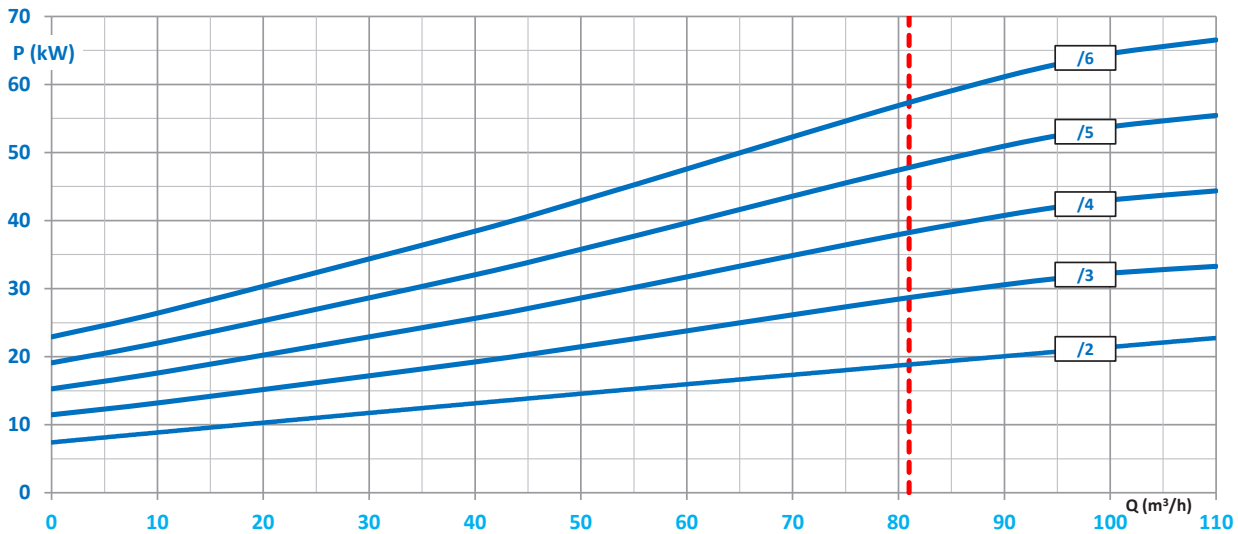
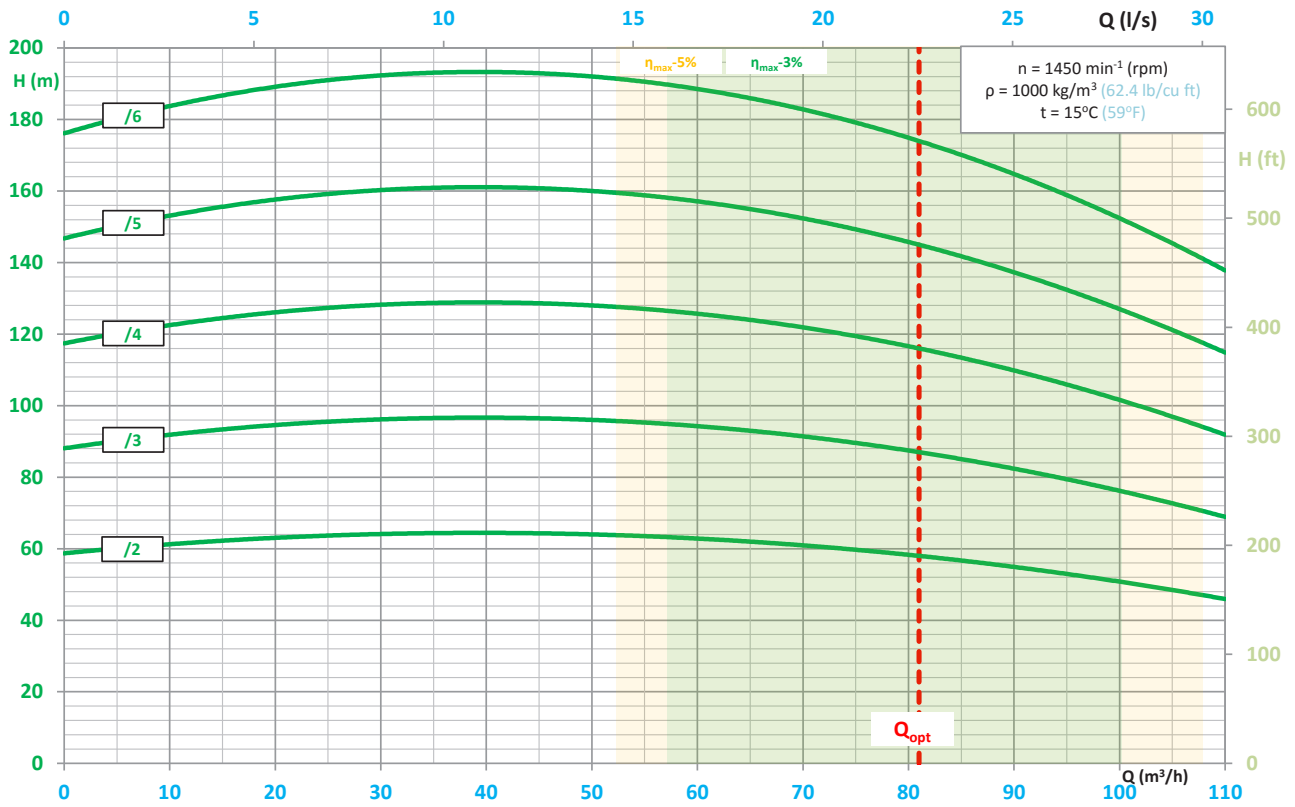

H_s , NPSH3	(m)	(ft)
8	26.2	
7	23.0	
6	19.7	
5	16.4	
4	13.1	
3	9.8	
2	6.6	
1	3.3	
0	0	

PUMP PERFORMANCE CURVE

PS-150Z

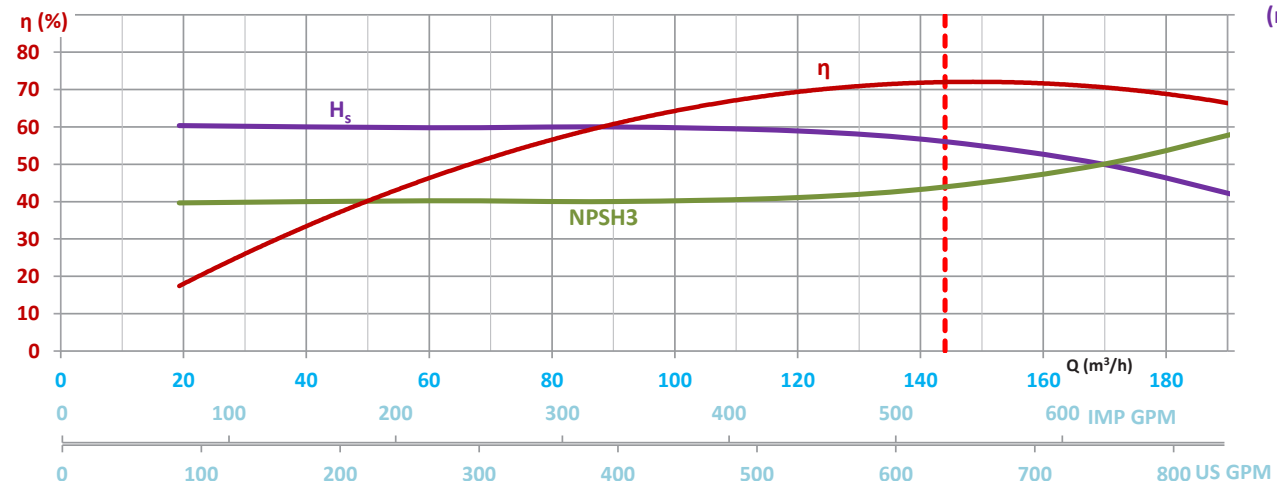
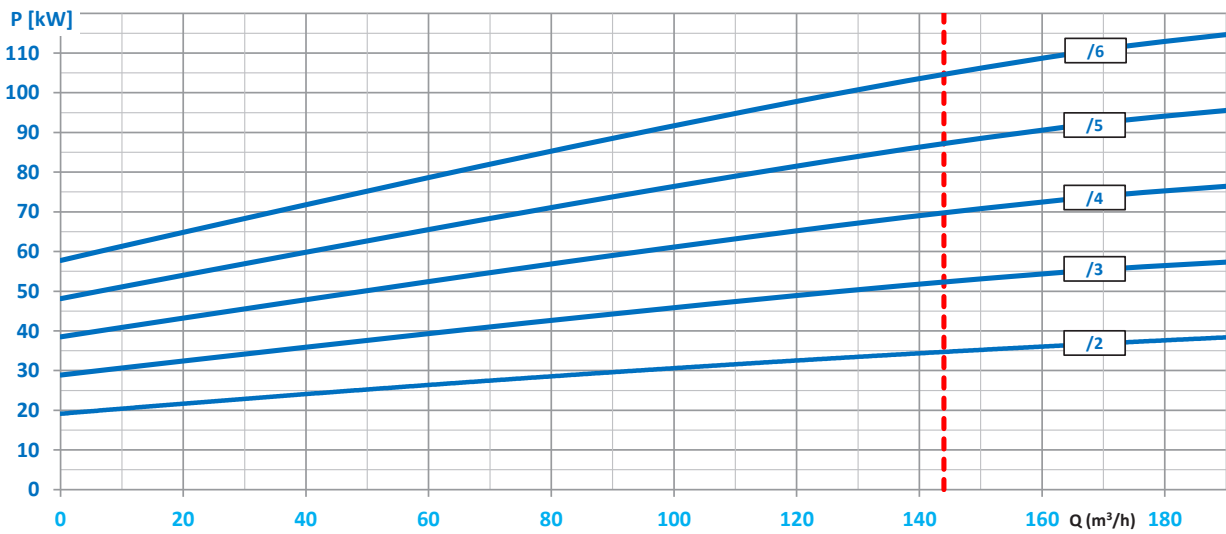
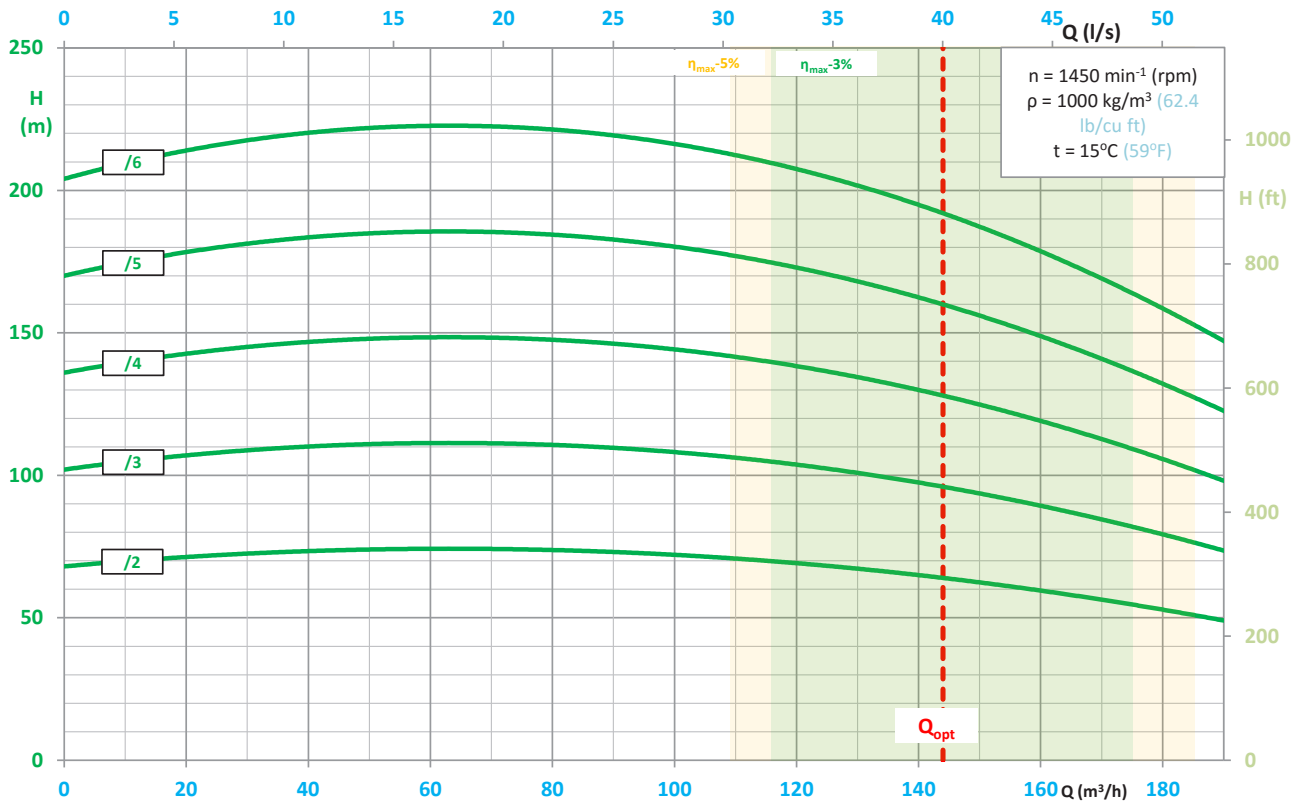

H_s , NPSH3	(m)	(ft)
8	26.2	
7	23.0	
6	19.7	
5	16.4	
4	13.1	
3	9.8	
2	6.6	
1	3.3	
0	0	

PS-200Z

PUMP PERFORMANCE CURVE

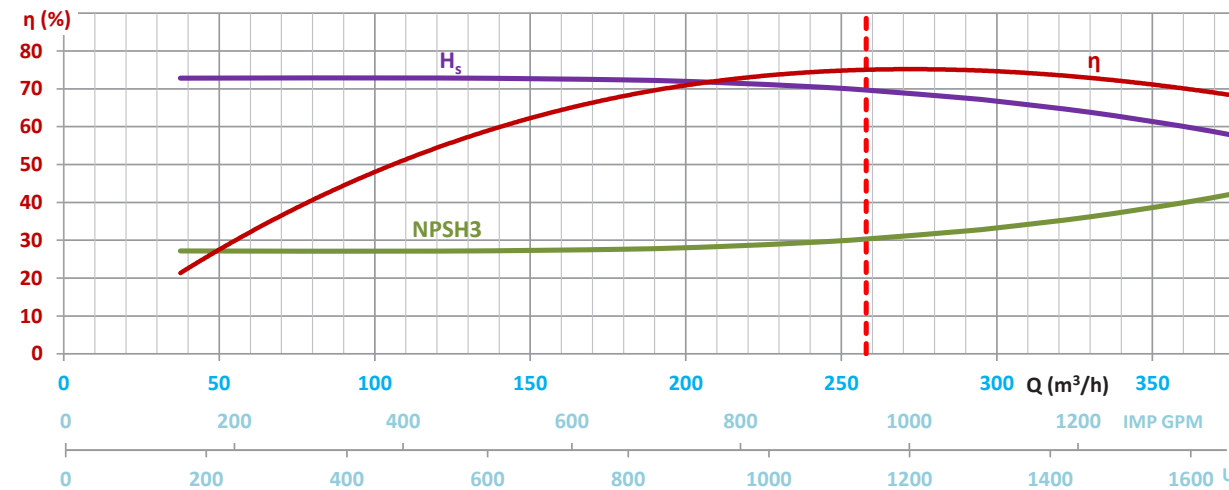
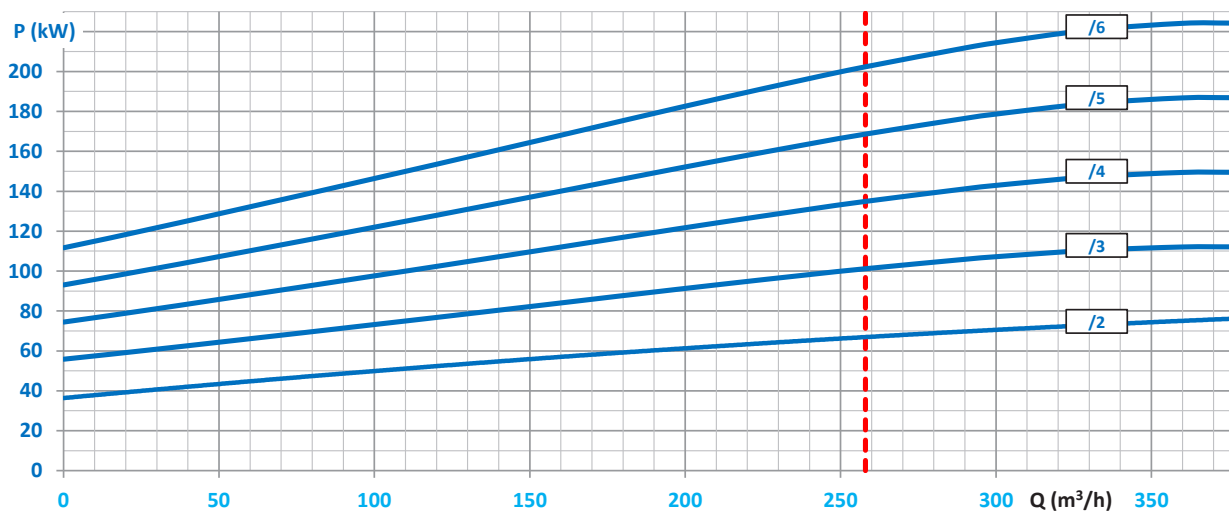
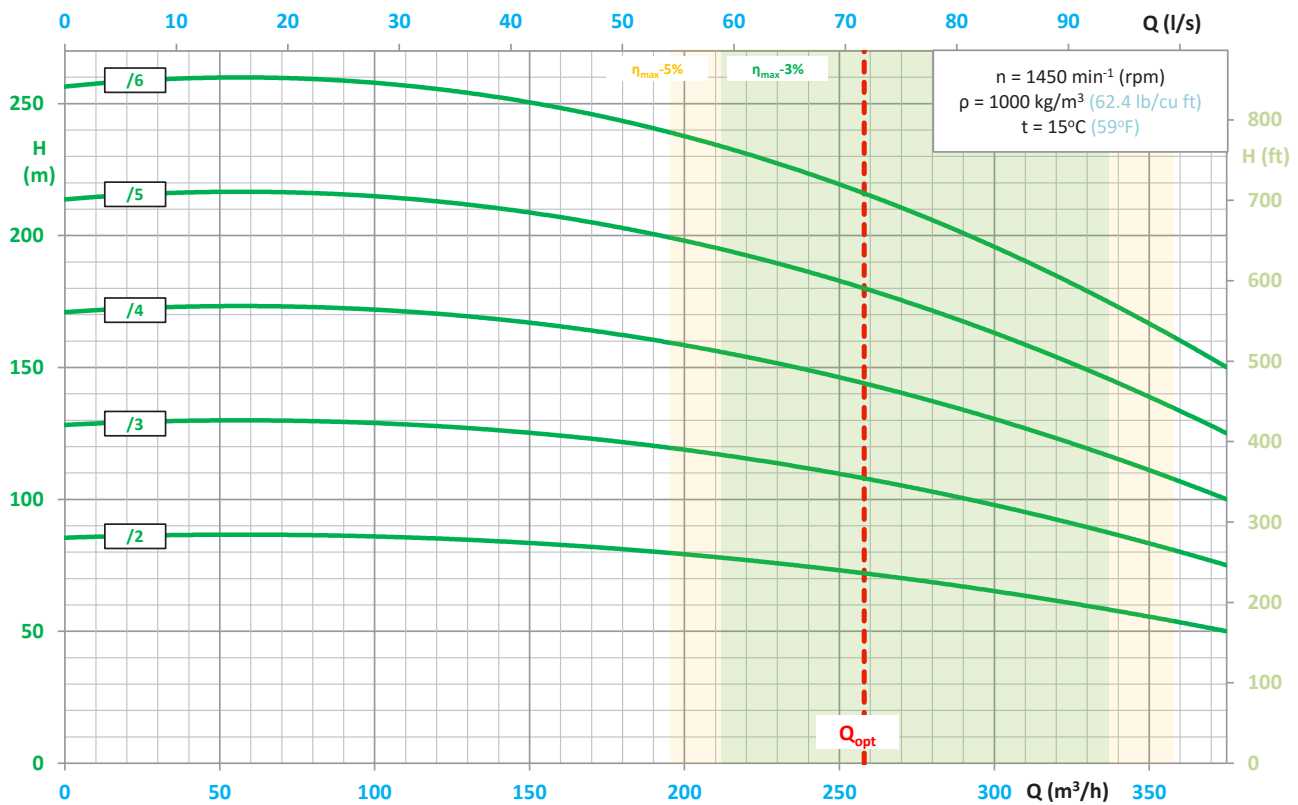

H_s , NPSH3	(m)	(ft)
8	26.2	
7	23.0	
6	19.7	
5	16.4	
4	13.1	
3	9.8	
2	6.6	
1	3.3	
0	0	



PUMP PERFORMANCE CURVE

PS-250Z

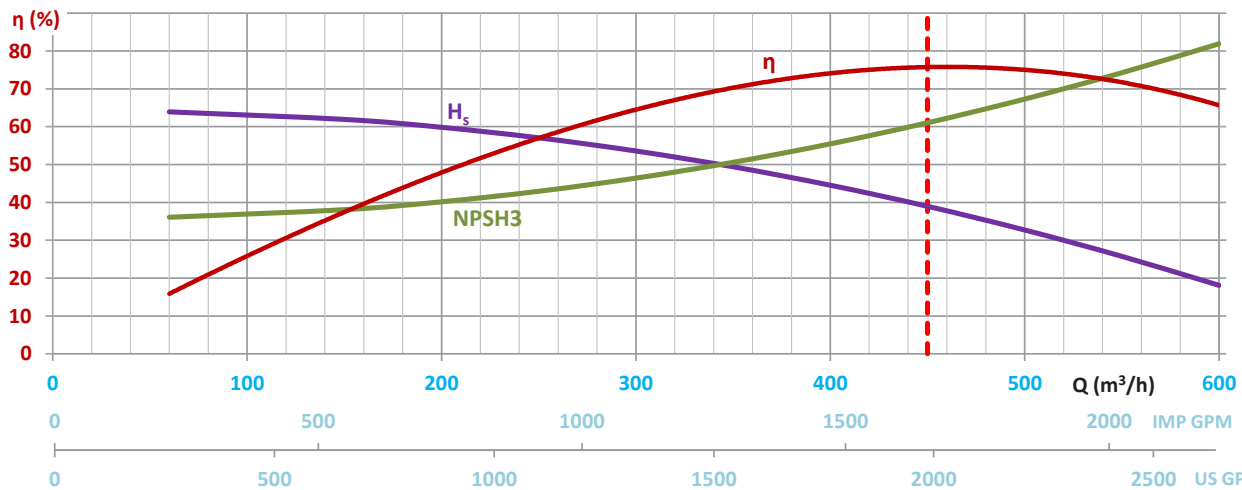
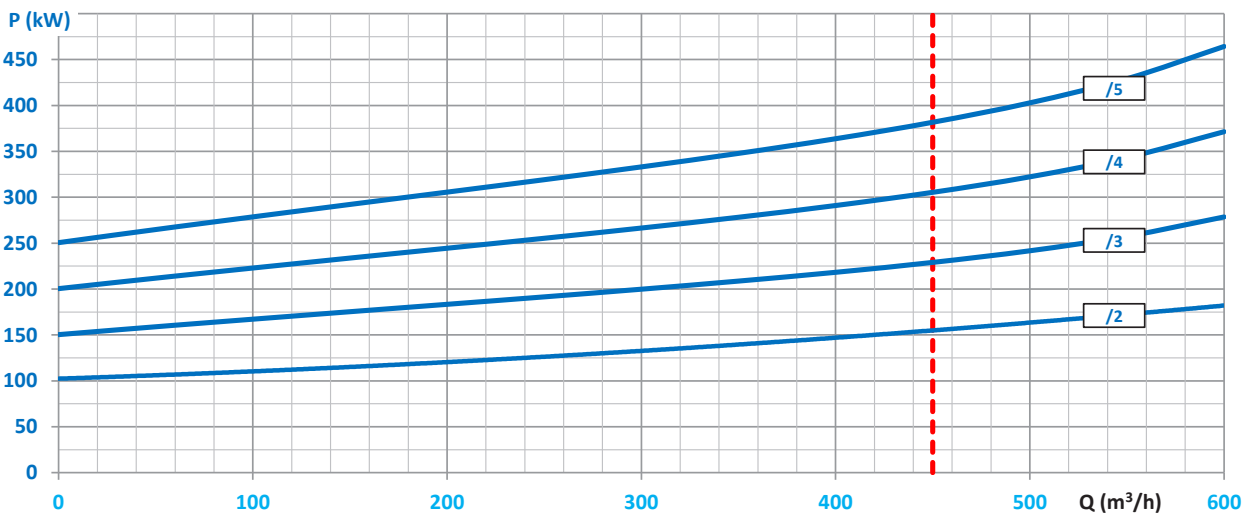
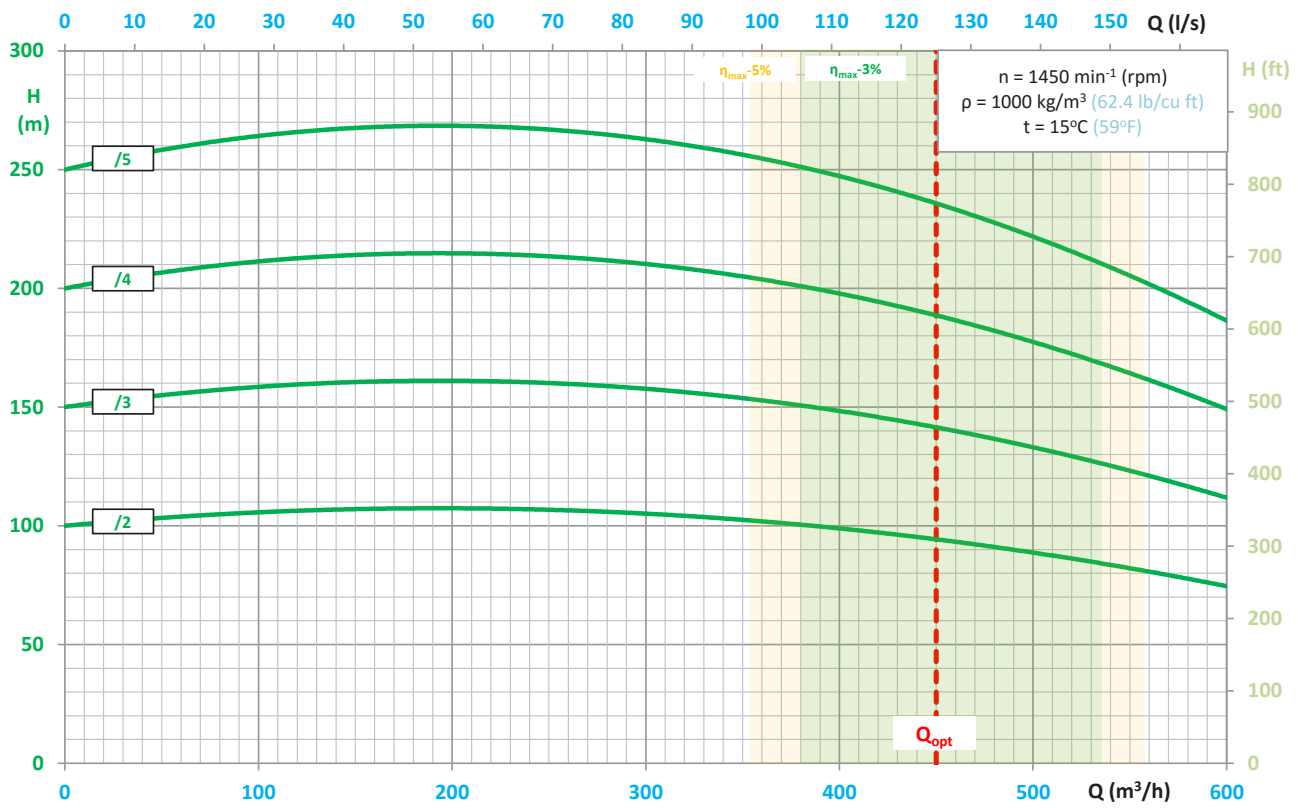

WPZ-50

IMPELLER FEED PUMP Type BB4

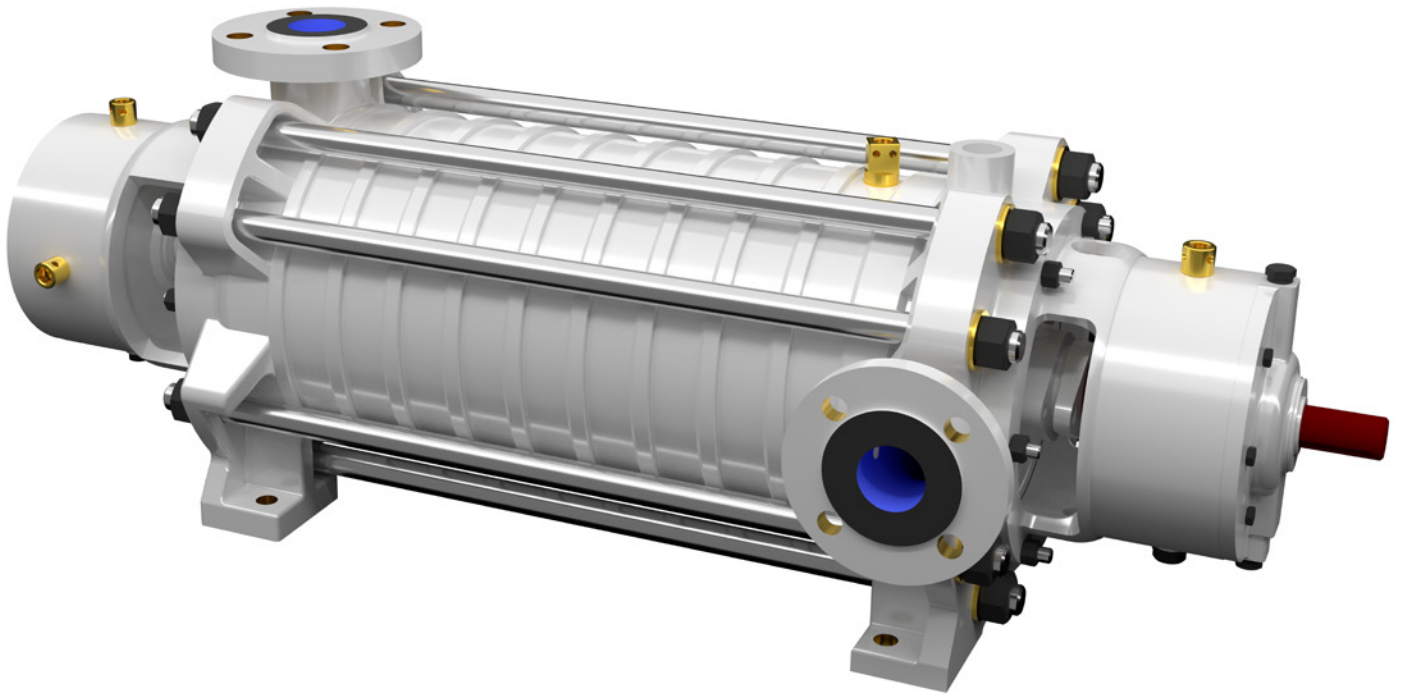

TYPICAL APPLICATIONS

- pumping of pure or mechanically contaminated water with solids with the grain size of up to 2 mm (5/64 inch),
- mining – spraying systems of the mining head,
- pressure boosting,
- technological processes,
- industrial systems,
- filtration systems.

KEY ADVANTAGES

- long life ensured by the use of state-of-the-art corrosion and erosion resistant materials,
- silent and smooth operation,
- inflow and suction operation,
- compact and modern design,
- approved for operation in explosion-hazard zones – ATEX Ex I M2.

PUMP PERFORMANCE CURVE

WPZ-50

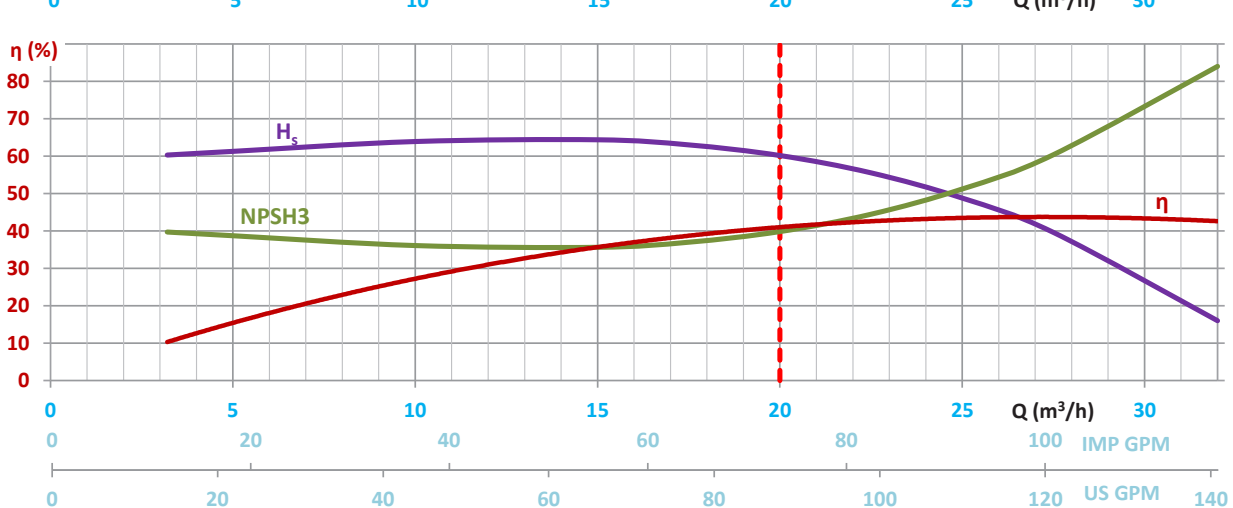
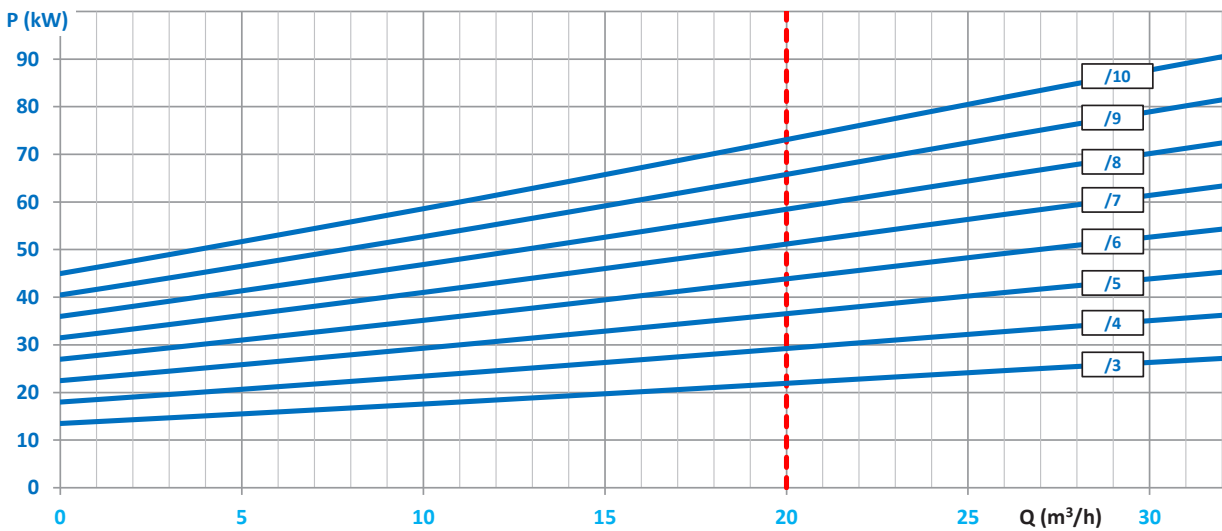
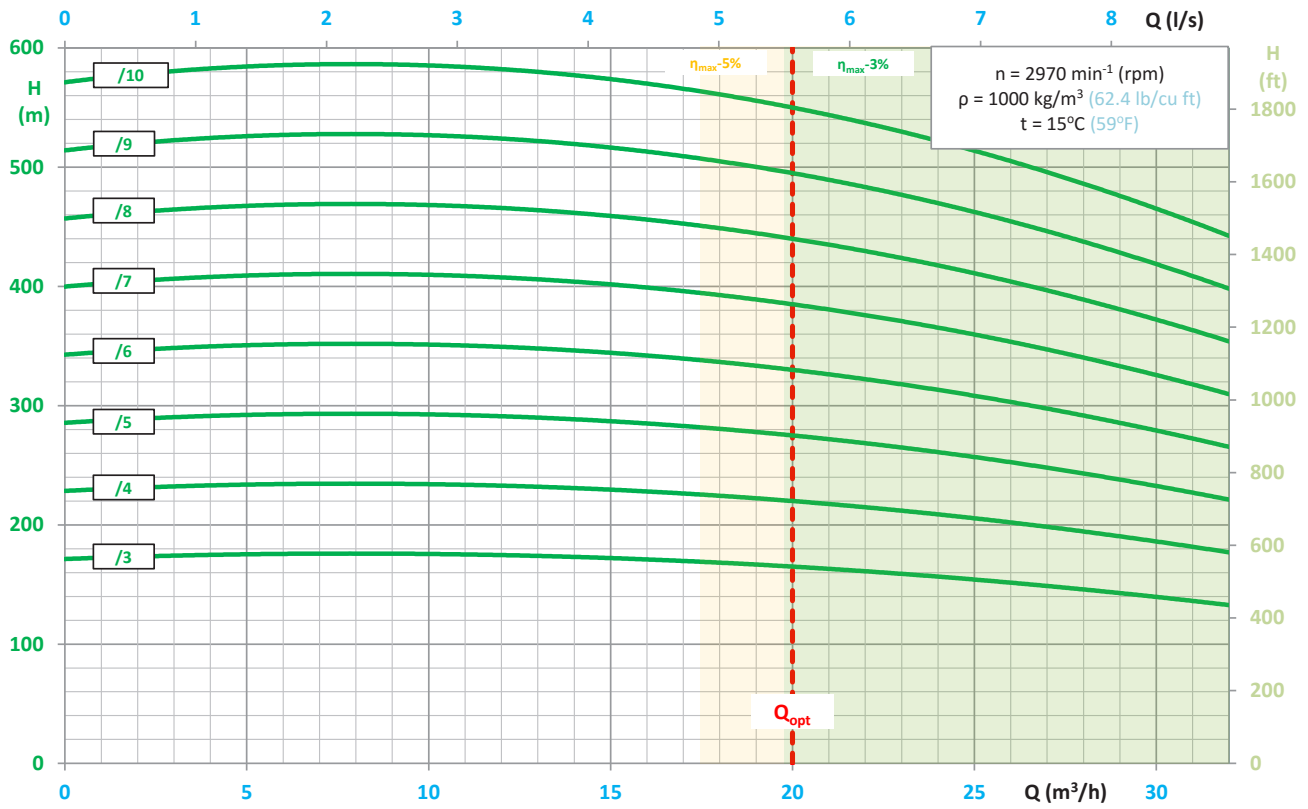



SINGLE-STAGE HYDROTRANSPORT IMPELLER PUMP

Type 0H1

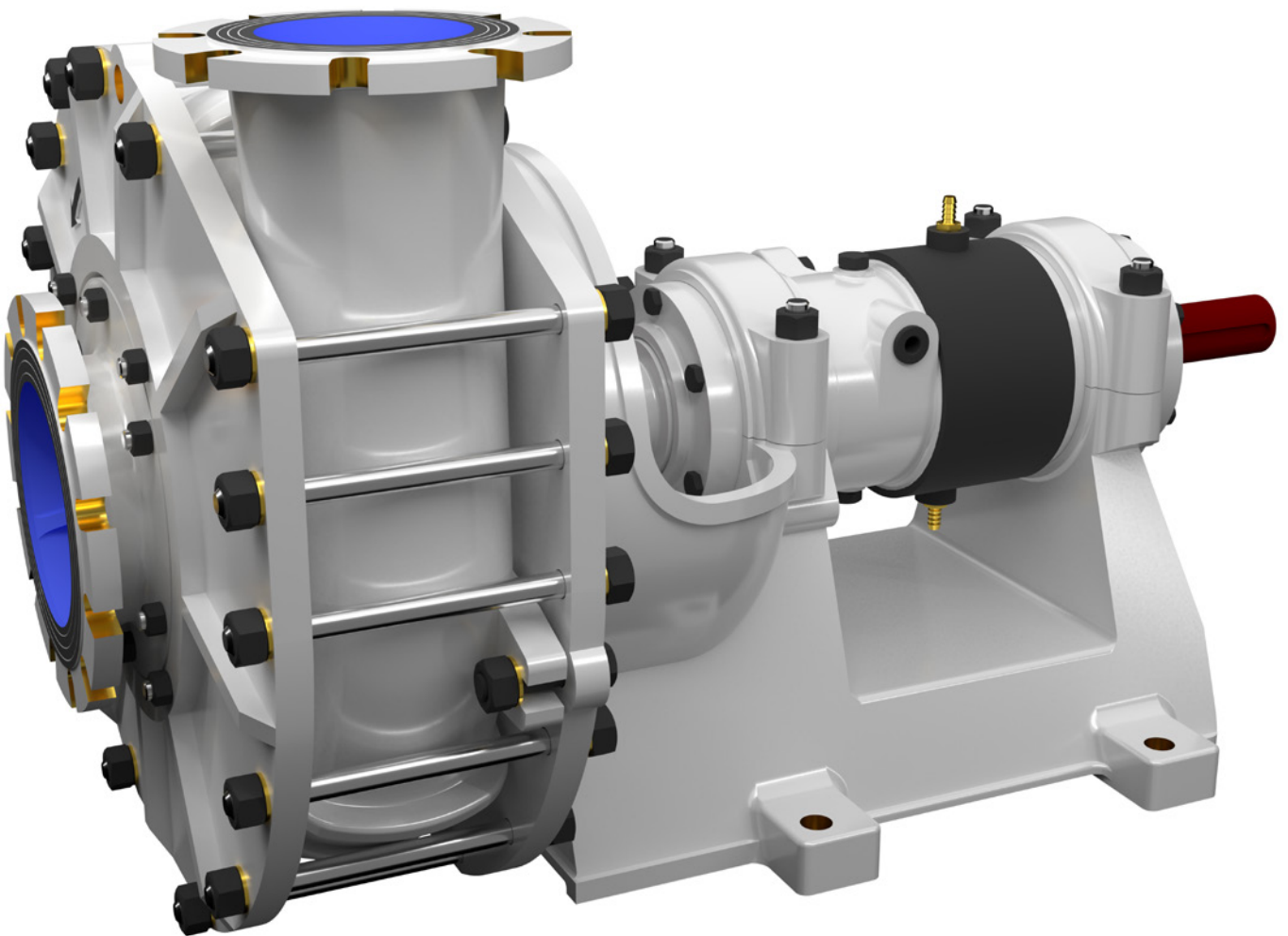

TYPICAL APPLICATIONS

- pumping mixtures with large grains and highly abrasive properties,
- pumping mixtures of water and quartz sand, ores, coal, slag, ash, etc.,
- mining – WPJ pumps intended to replace hydrotransport drainage pumps used so far,
- water supply systems,
- pressure boosting,
- technological processes,
- industrial systems,
- hydrocyclons,
- filtration systems.

KEY ADVANTAGES

- long life ensured by the use of state-of-the-art corrosion and erosion resistant materials,
- possibility of operation with a frequency converter,
- possibility of serial operation,
- the pumped mixture density can reach $\rho_{\max} = 1700 \text{ kg/m}^3$ (106,1 lb/cu ft) while pumping mixtures with a 50% content of solids in water,
- pumping mixture with density up to $\rho = 2200 \text{ kg/m}^3$ (137,3 lb/cu ft) by grain size up to 2 mm (5/64 inch) and low RPM,
- silent and smooth operation
- connection dimensions in compliance with hydrotransport pumps,
- inflow and suction operation,
- approved for operation in explosion-hazard zones – ATEX Ex I M2.

	Max. permissible size of solids	Smallest flow cross-section
WPJ - 100	14 mm / 0.6 in	20 mm / 0.8 in
WPJ - 150	42 mm / 1.7 in	60 mm / 2.4 in
WPJ - 150-R	55 mm / 2.2 in	60 mm / 2.4 in
WPJ - 200	57 mm / 2.2 in	80 mm / 3.1 in
WPJ - 250	54 mm / 2.1 in	80 mm / 3.1 in

NOMINAL OPERATION PARAMETERS AT PURE WATER PUMPING (for the maximum rotational speed and the biggest impeller)

Pump type	Q _n				H _n		n	D _z		P _n	m	
	m ³ /h	l/s	IMP GPM	US GPM	m	ft	rmp	mm	in	kW	kg	lb
WPJ - 100	130	36,1	572	477	42	138	1470	370	14.6	21	420	926
WPJ - 150	360	100	1585	1321	69	226	1480	450	17.7	92	755	1664
WPJ - 150-R	360	100	1585	1321	69	226	1480	450	17.7	92	755	1664
WPJ - 200	500	138,9	2202	1835	90	295	1485	526	20.7	190	1030	2271
WPJ - 250	1000	277,8	4403	3670	100	328	1485	580	22.8	371	1800	3968

The pump construction makes it possible to reduce the operation parameters via a reduction of rpm and/or a reduction of the impeller diameter, thus adjusting the pump to the System without the need for throttling.

PHZ

HYDROTRANSPORT
PUMP
Type OH1

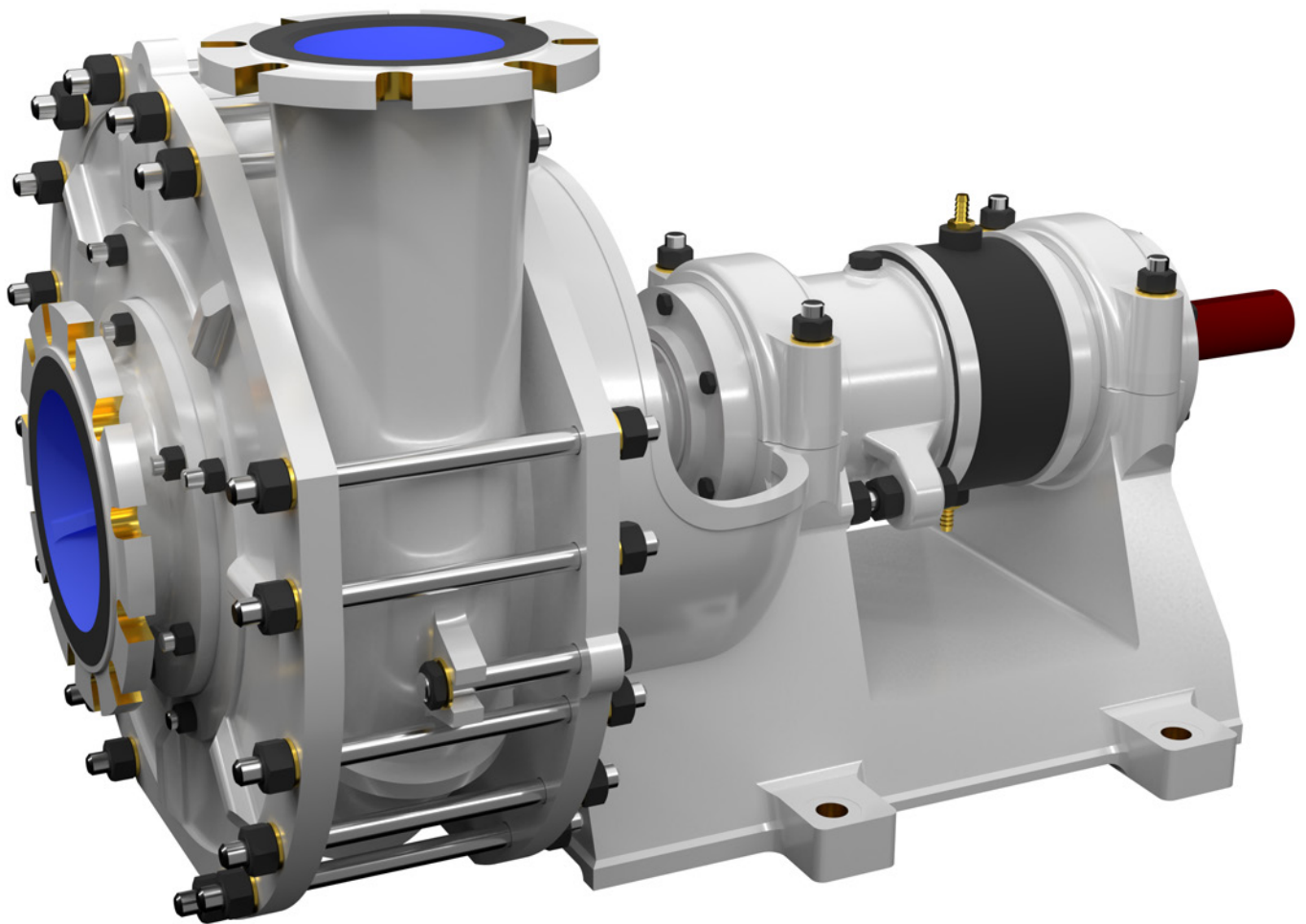

TYPICAL APPLICATIONS

- with large grains and highly abrasive properties,
- pumping mixtures of water and quartz sand, ores, coal, slag, ash, etc.,
- mining – PHZ pumps intended to replace hydrotransport drainage pumps used so far,
- water supply systems,
- pressure boosting,
- technological processes,
- industrial systems,
- hydrocyclons,
- filtration systems.

KEY ADVANTAGES

- long life ensured by the use of state-of-the-art corrosion and erosion resistant materials,
- possibility of operation with a frequency converter,
- possibility of serial operation,
- the pumped mixture density can reach $\rho_{max} = 1700 \text{ kg/m}^3$ (106,1 lb/cu ft) while pumping mixtures with a 50% content of solids in water,
- pumping mixture with density up to $\rho = 2200 \text{ kg/m}^3$ (137,3 lb/cu ft) by grain size up to 2 mm (5/64 inch) and low RPM,
- silent and smooth operation
- connection dimensions in compliance with hydrotransport pumps,
- inflow and suction operation,
- approved for operation in explosion-hazard zones – ATEX Ex I M2.

	Max. permissible size of solids
PHZ - 100	14 mm / 0.6 in
PHZ - 150	42 mm / 1.7 in
PHZ - 200	50 mm / 2.0 in
PHZ - 250	52 mm / 2.0 in
PHZ - 300	50 mm / 2.0 in

NOMINAL OPERATION PARAMETERS AT PURE WATER PUMPING (for the maximum rotational speed and the biggest impeller)

Pump type	Q _n				H _n		n	D _z		P _n	m	
	m ³ /h	l/s	IMP GPM	US GPM	m	ft	rmp	mm	in	kW	kg	lb
PHZ - 100	125	34,7	550	459	40	131	1600	332	13.1	21	359	791
PHZ - 150	315	87,5	1387	1156	63	207	1450	440	17.3	75	720	1587
PHZ - 200	500	138,9	2202	1835	80	262	1450	504	19.8	168	1230	2712
PHZ - 250	960	266,7	4227	3523	90	295	1450	570	22.44	308	1522	3355
PHZ - 300	1400	388,9	6164	5138	73	239	980	725	28.5	357	2646	5833

The pump construction makes it possible to reduce the operation parameters via a reduction of rpm and/or a reduction of the impeller diameter, thus adjusting the pump to the System without the need for throttling.

WPCC

HEAVY DUTY
IMPELLER PUMP
Type 0H1

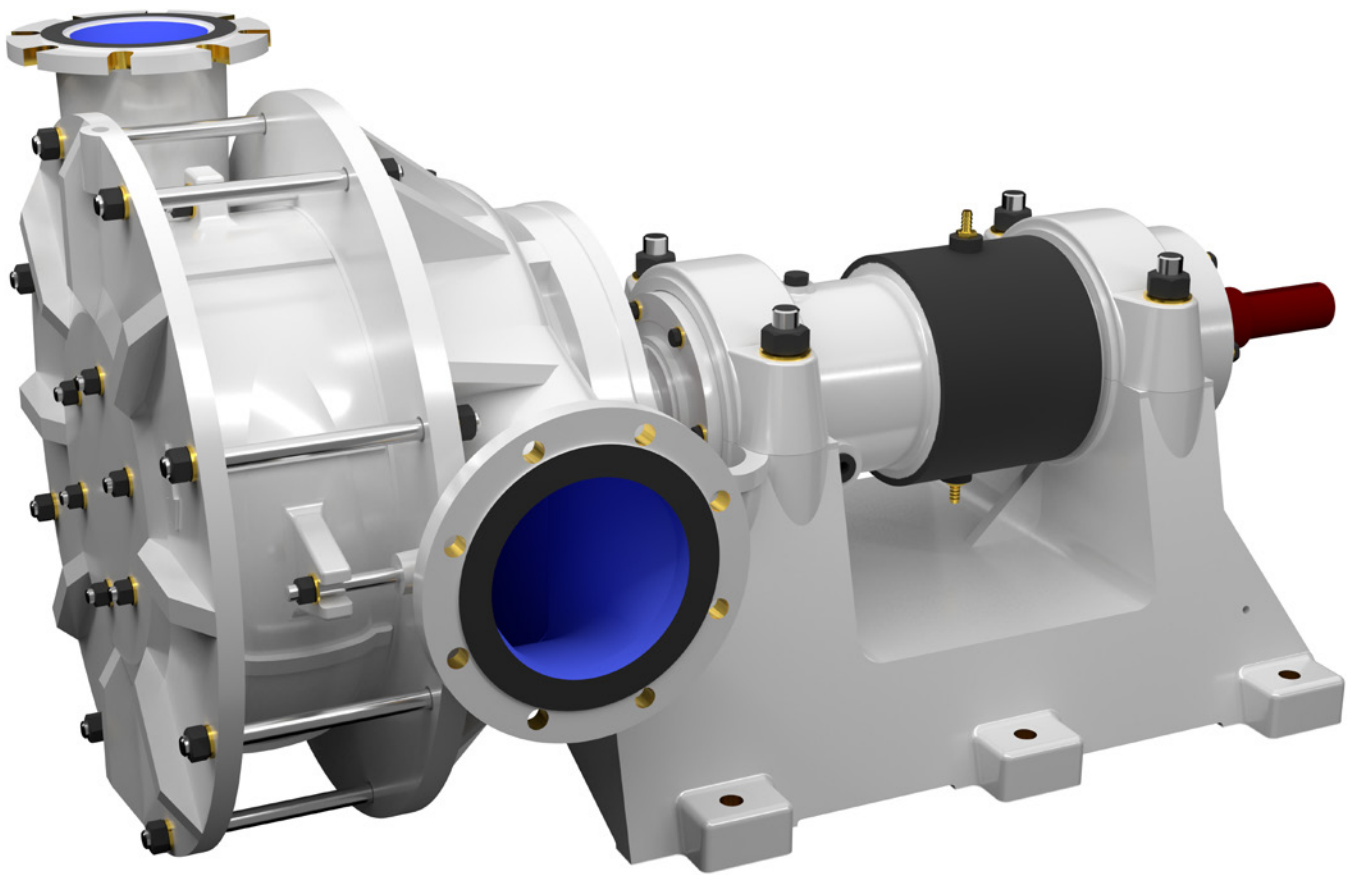

TYPICAL APPLICATIONS

- pumping mixtures of water and solids,
- with large grains and highly abrasive properties,
- pumping mixtures of water and quartz sand,
- ores, coal, slag, ash,
- mining – WPCC pumps intended to replace heavy duty pumps used so far for,
- technological processes,
- industrial systems,
- filtration systems.

KEY ADVANTAGES

- long life ensured by the use of state-of-the-art corrosion and erosion resistant materials,
- possibility of operation with a frequency converter,
- possibility of serial operation,
- the pumped mixture density can reach $\rho_{\max} = 2200 \text{ kg/m}^3$ (137,3 lb/cu ft) while pumping mixtures with a 50% content of solids in water,
- silent and smooth operation
- connection dimensions in compliance with heavy duty pumps,
- inflow and suction operation,
- approved for operation in explosion-hazard zones – ATEX Ex I M2.

	Max. permissible size of solids	Smallest flow cross-section
WPCC - 80	22 mm / 0.9 in	34 mm / 1.3 in
WPCC - 100	28 mm / 1.1 in	40 mm / 1.6 in
WPCC - 150	40 mm / 1.6 in	68 mm / 2.7 in

NOMINAL OPERATION PARAMETERS AT PURE WATER PUMPING (for the maximum rotational speed and the biggest impeller)

Pump type	Q _n				H _n		n	D _z		P _n	m	
	m ³ /h	l/s	IMP GPM	US GPM	m	ft		mm	in		kg	lb
WPCC - 80	90	25,0	396,3	330,3	19	62	960	375	14.8	8,5	713	1572
WPCC - 100	165	45,8	726,5	605,6	20,5	67	960	400	15.7	13,5	848	1870
WPCC - 150	300	83,3	1320,9	1101	17	56	850	428	16.9	18,6	989	2180

The pump construction makes it possible to reduce the operation parameters via a reduction of rpm and/or a reduction of the impeller diameter, thus adjusting the pump to the System without the need for throttling.

SPW-150

HIGH SPEED IMPELLER PUMP Type BB4

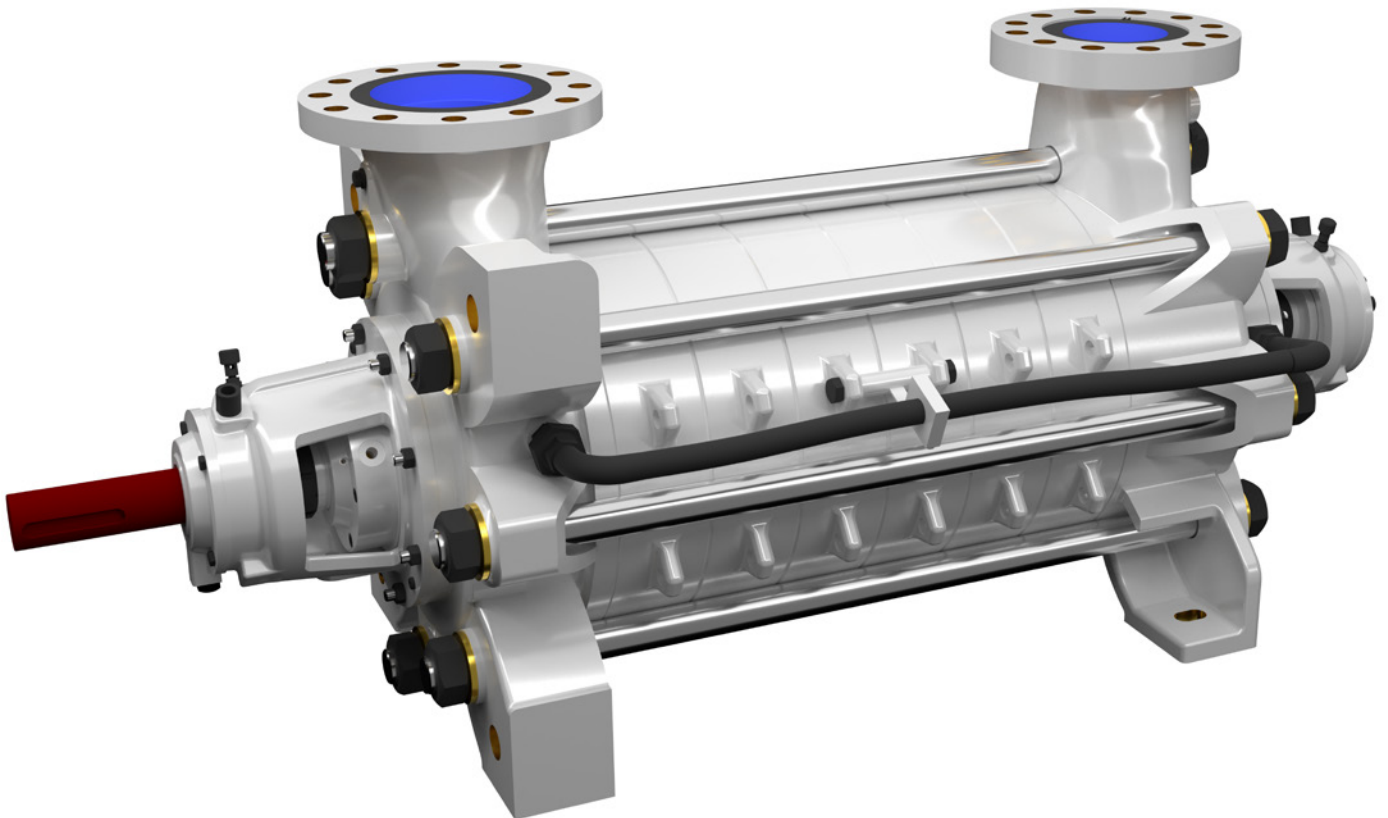

TYPICAL APPLICATIONS

- pumping of pure or mechanically contaminated water with solids with the grain size of up to 2 mm (5/64 inch),
- pressure boosting,
- technological processes,
- industrial systems,
- coal, copper, salt and other mines,
- mining – main and auxiliary dewatering.

KEY ADVANTAGES

- different material executions up to DUPLEX and SUPER DUPLEX ensuring the longest life time and corrosion and erosion resistance,
- possibility to use an electronic system for the balance disk wear monitoring,
- possibility to use mechanical sealing,
- possibility of rotating suction connector every 90°,
- highest workmanship precision due to use of multiaxial machines,
- high precision balancing of rotating unit,
- approved for operation in explosion-hazard-zones – ATEX Ex I M2.

PUMP PERFORMANCE CURVE

SPW-150

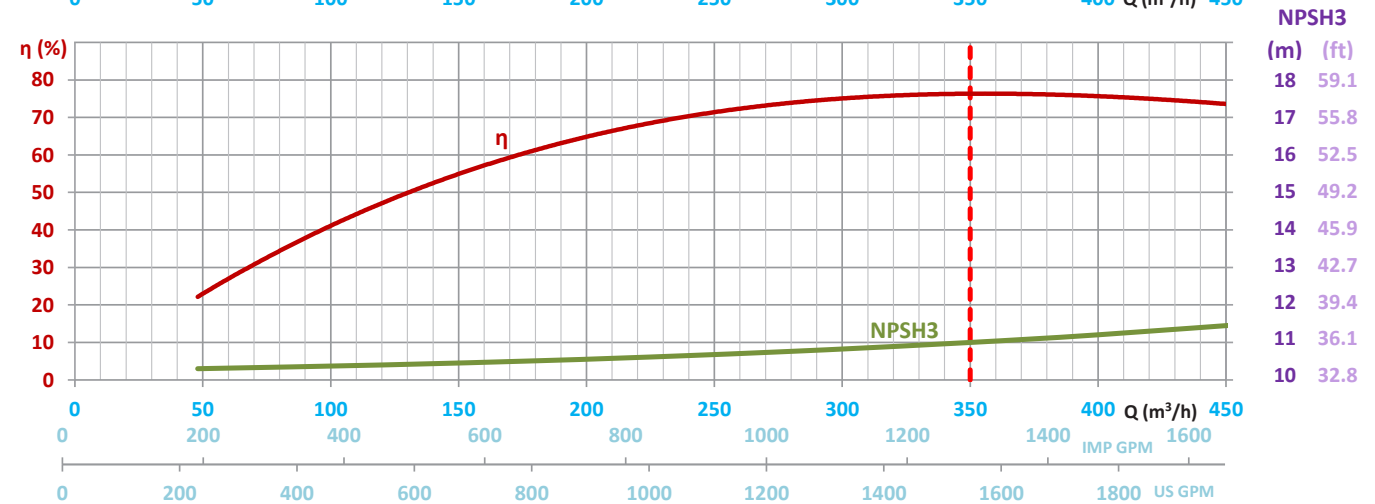
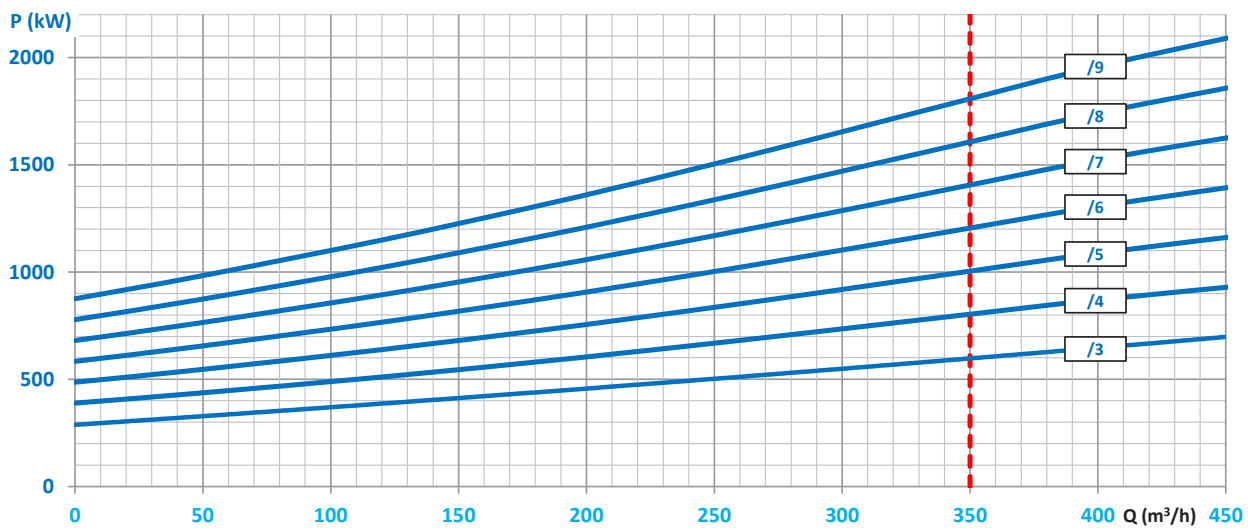
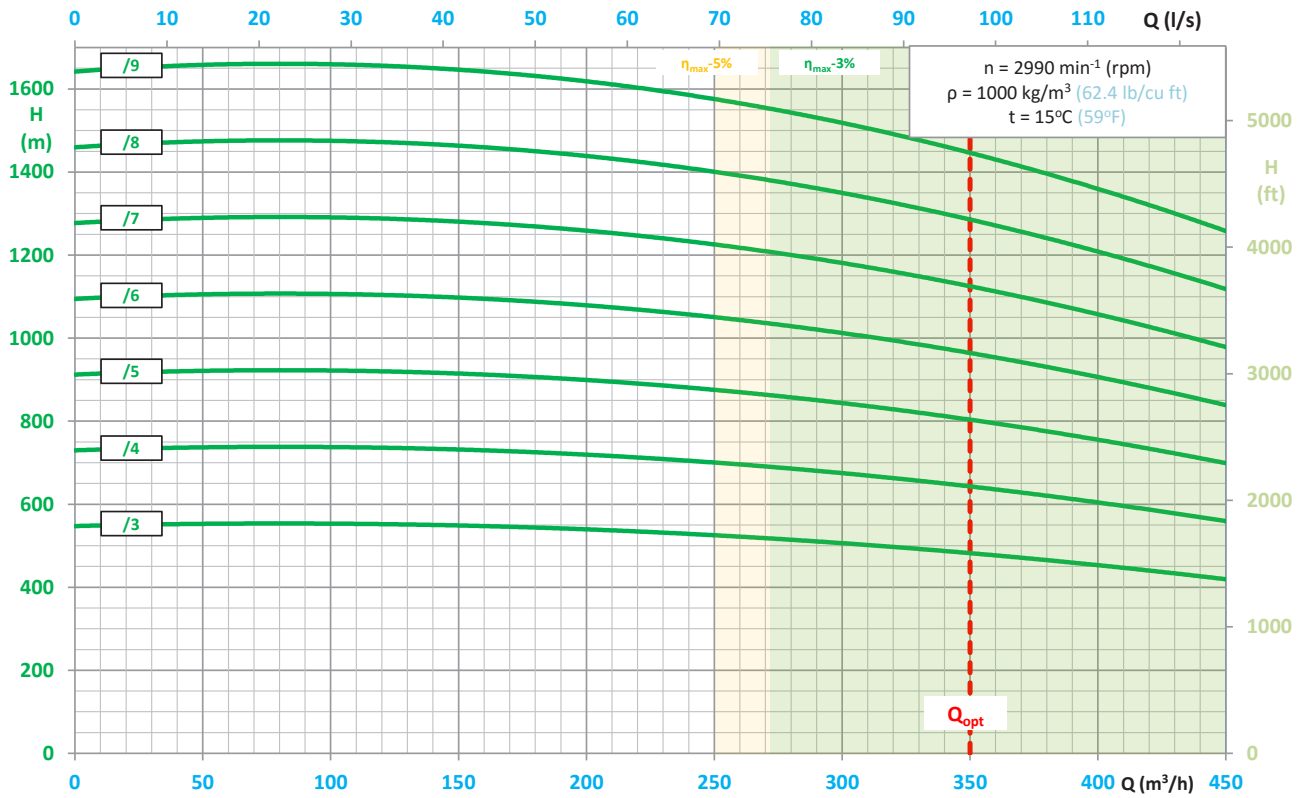

HIGH PRESSURE IMPELLER PUMPS

Type BB4

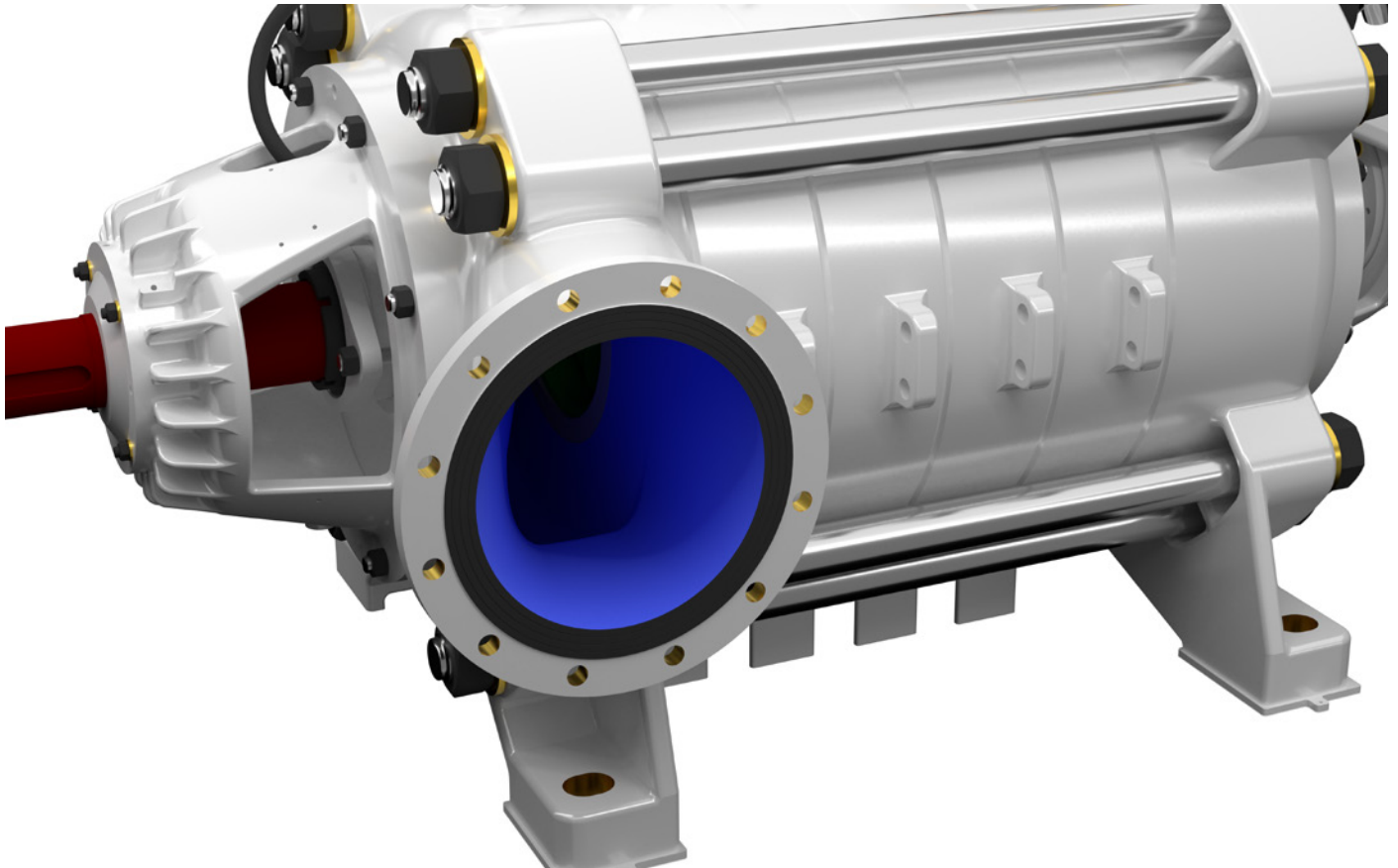

TYPICAL APPLICATIONS

- pumping of pure or mechanically contaminated water with solids with the grain size of up to 2 mm,
- pressure boosting,
- technological processes,
- industrial systems,
- coal, copper, salt and other mines,
- mining – main and auxiliary dewatering.

KEY ADVANTAGES

- new design with high efficiency
- long life ensured by the use of state-of-the-art corrosion and erosion resistant materials (salt-resistant workmanship),
- special material execution DUPLEX especially resistant to difficult conditions,
- possibility to use an electronic system of the balance disk wear monitoring,
- approved for operation in explosion-hazard zones – ATEX Ex I M2.

PUMP PERFORMANCE CURVE

WPWE-100R_z

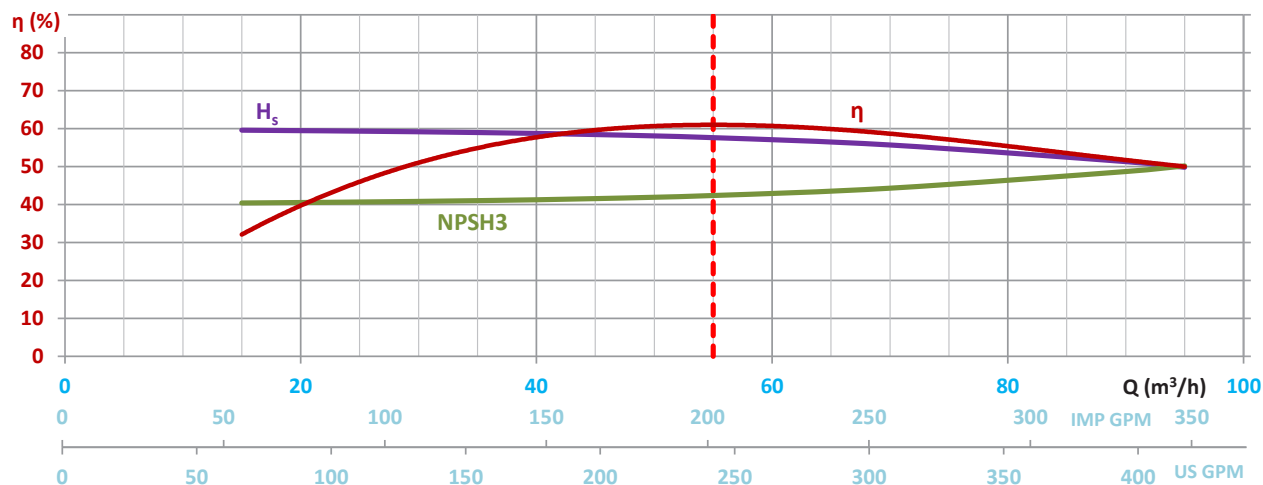
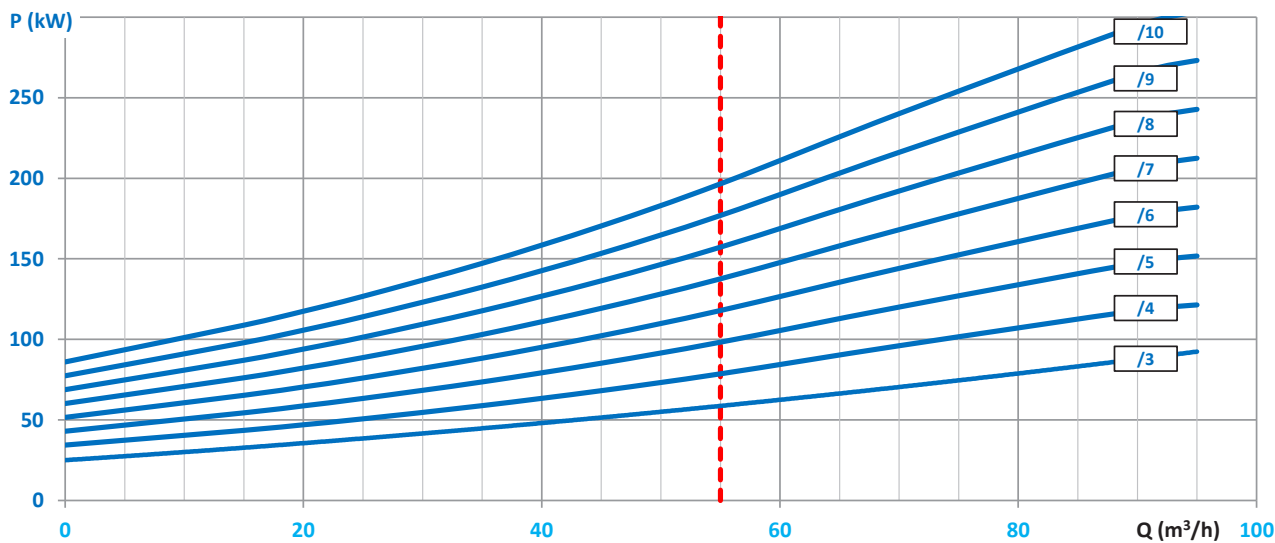
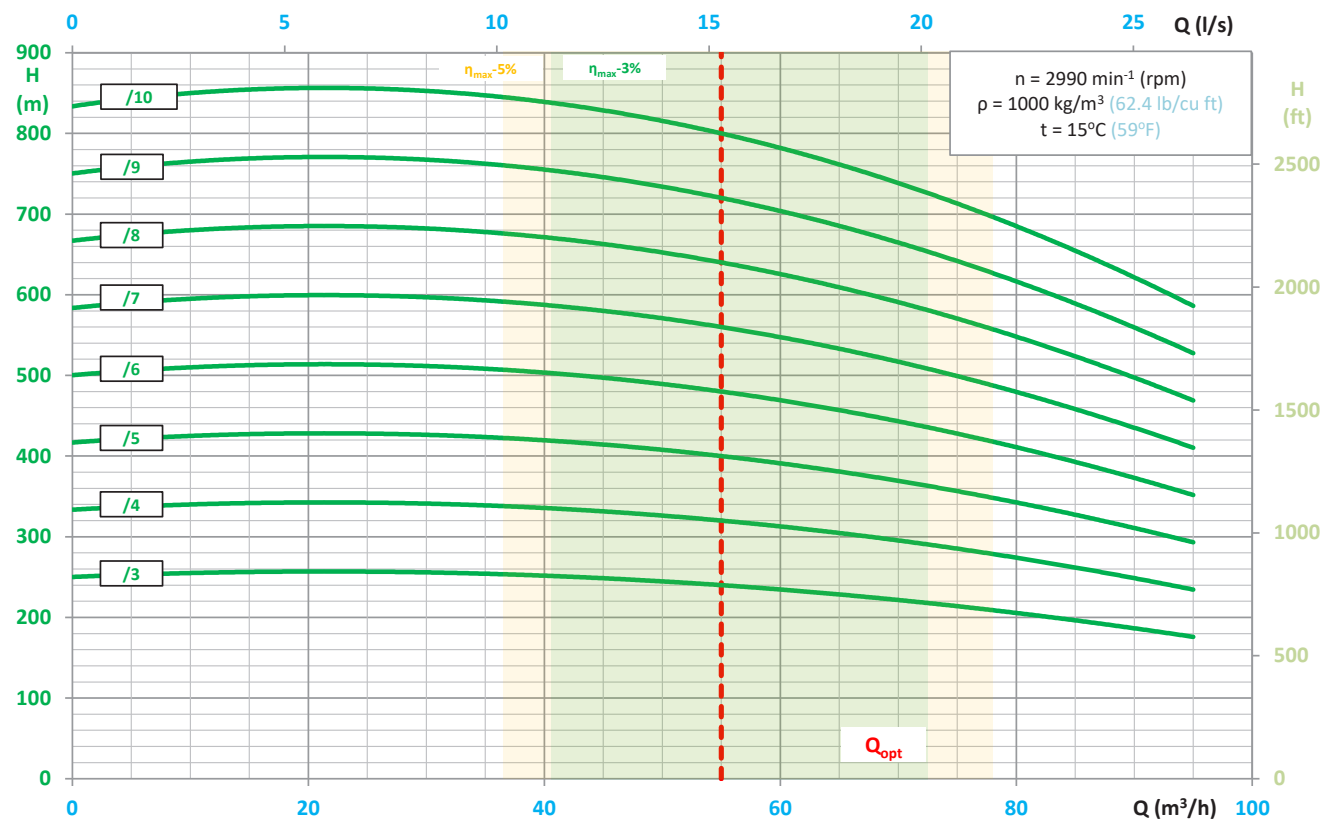

H_s , NPSH3 (m)	(ft)
8	26.2
7	23.0
6	19.7
5	16.4
4	13.1
3	9.8
2	6.6
1	3.3
0	0

WPWE-100

PUMP PERFORMANCE CURVE

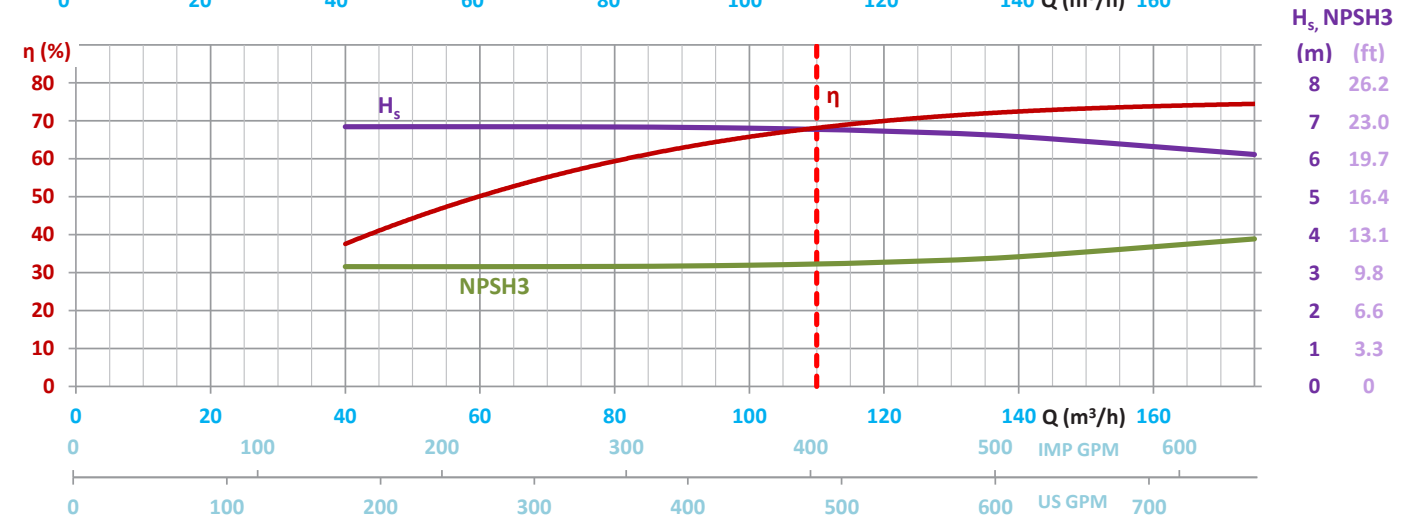
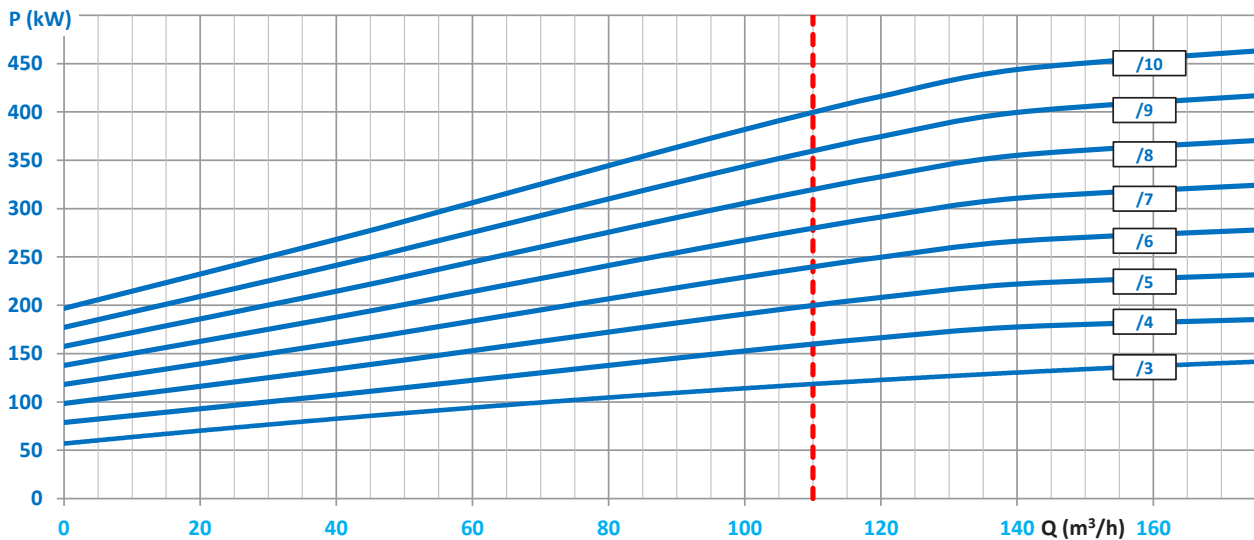
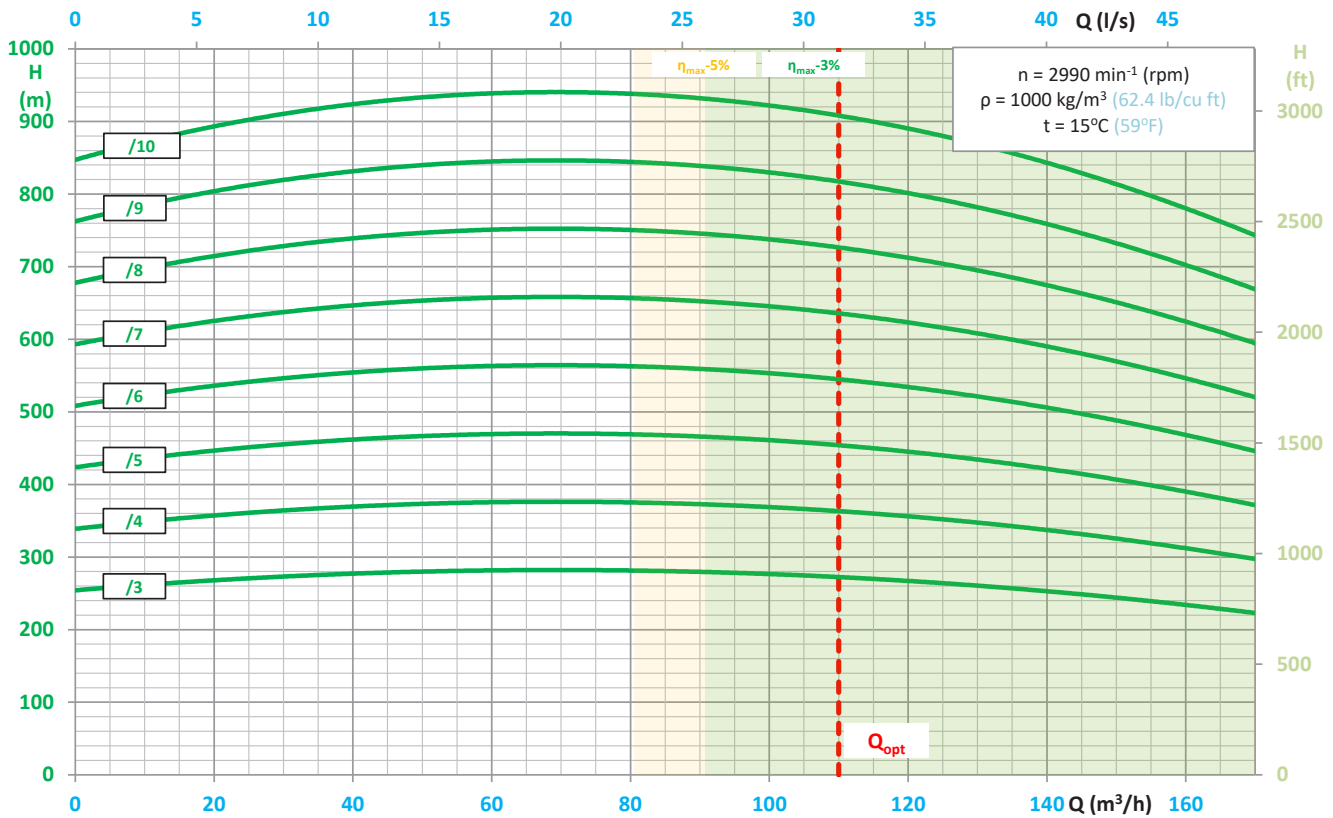

PUMP PERFORMANCE CURVE

WPWE-150

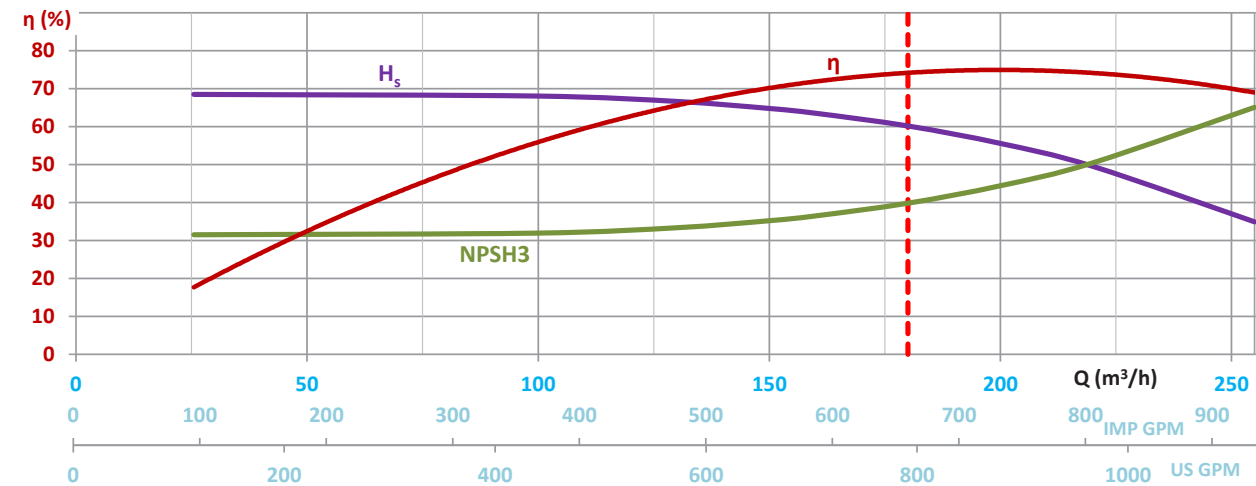
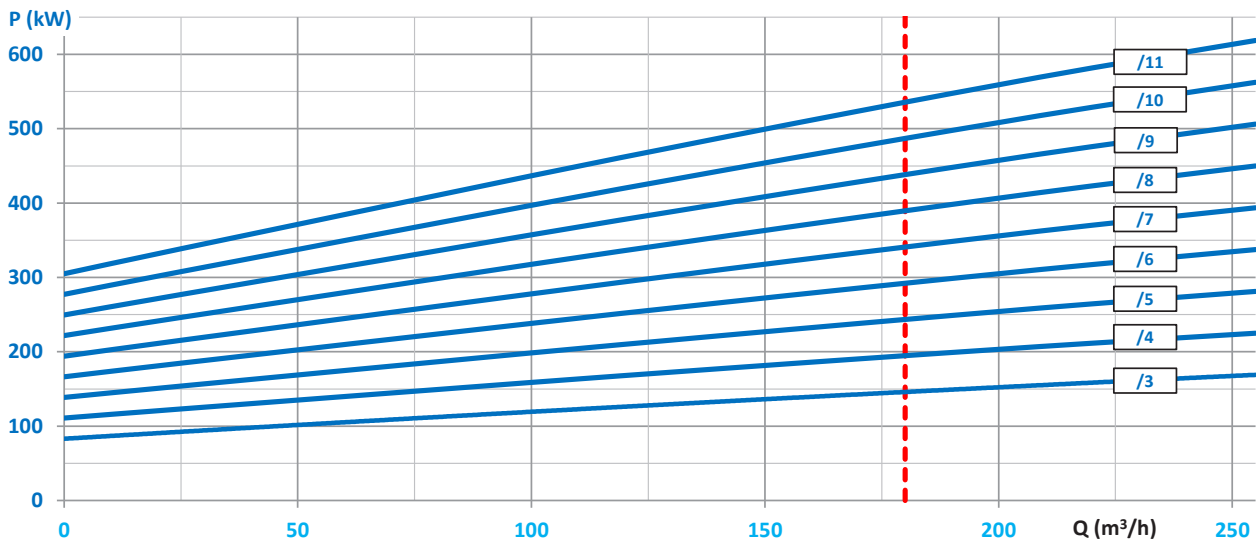
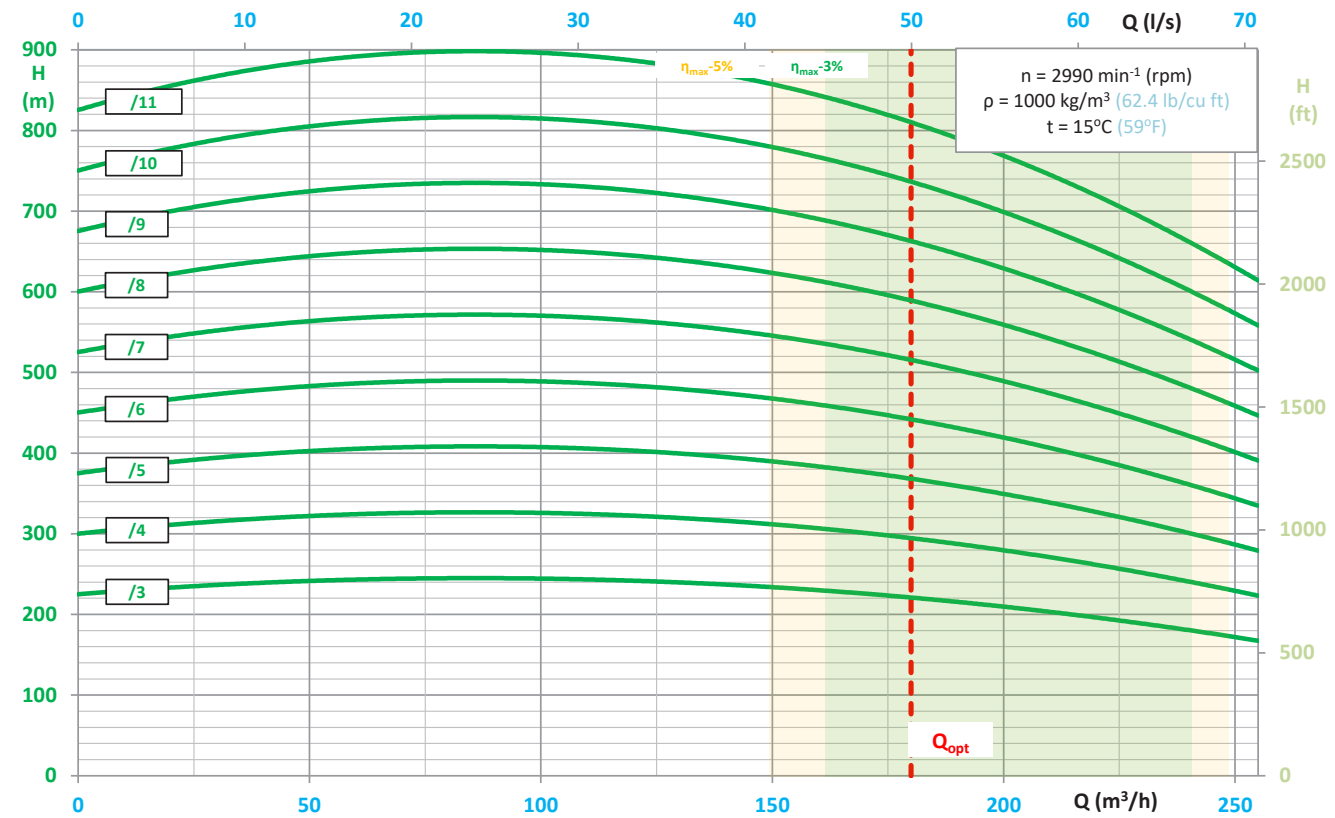

H_s , NPSH3	(m)	(ft)
8	26.2	
7	23.0	
6	19.7	
5	16.4	
4	13.1	
3	9.8	
2	6.6	
1	3.3	
0	0	

WPWE-200

PUMP PERFORMANCE CURVE

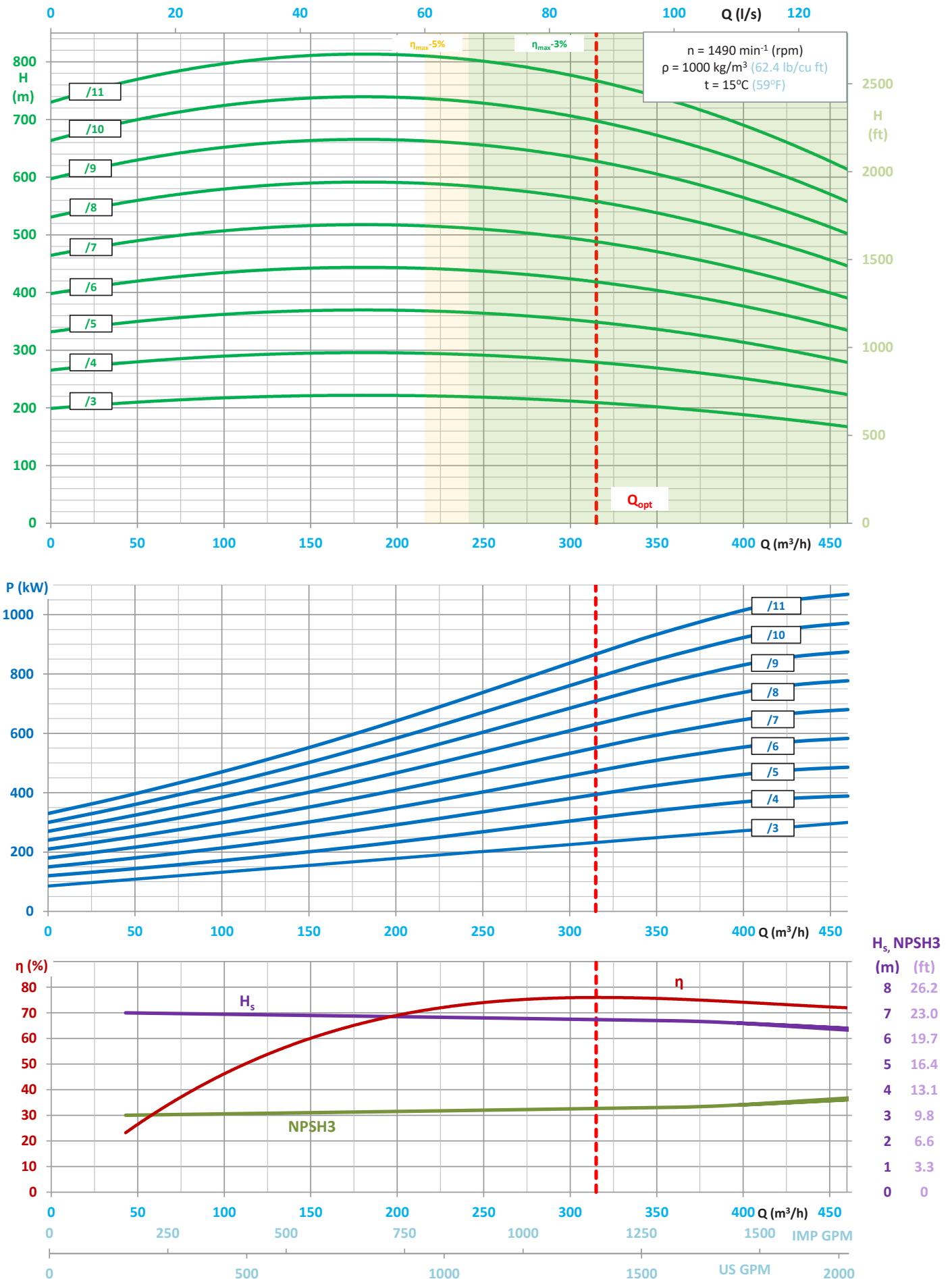

PUMP PERFORMANCE CURVE

WPWE-250

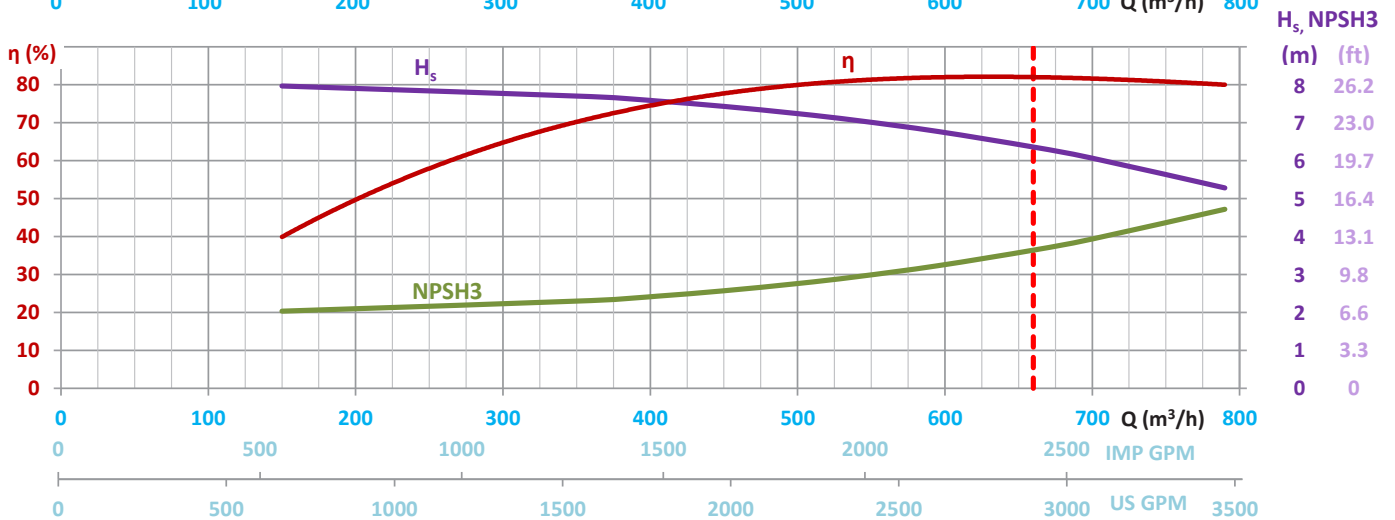
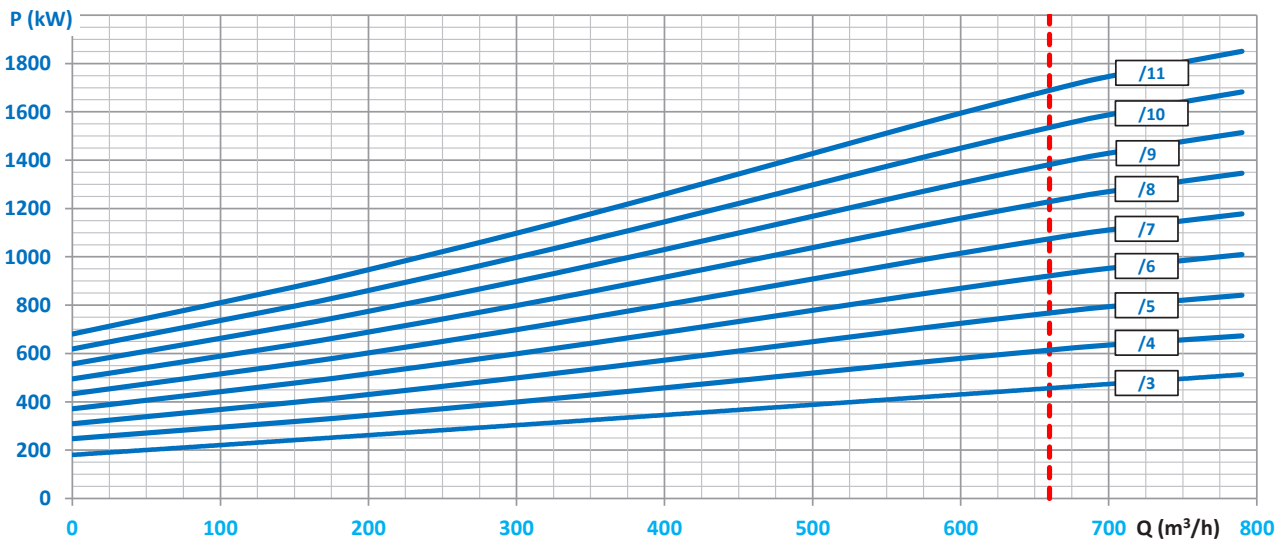
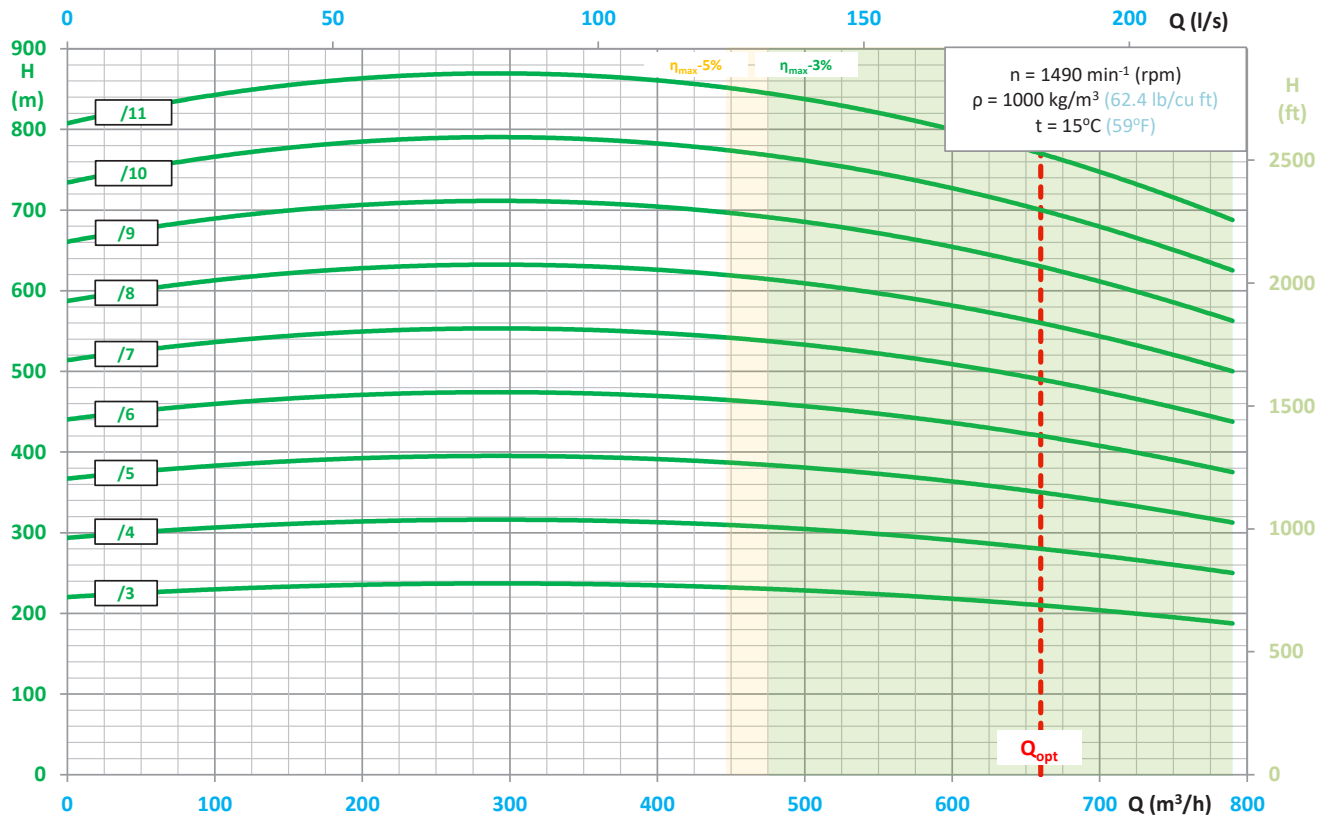

HIGH PRESSURE IMPELLER PUMPS

Type BB4

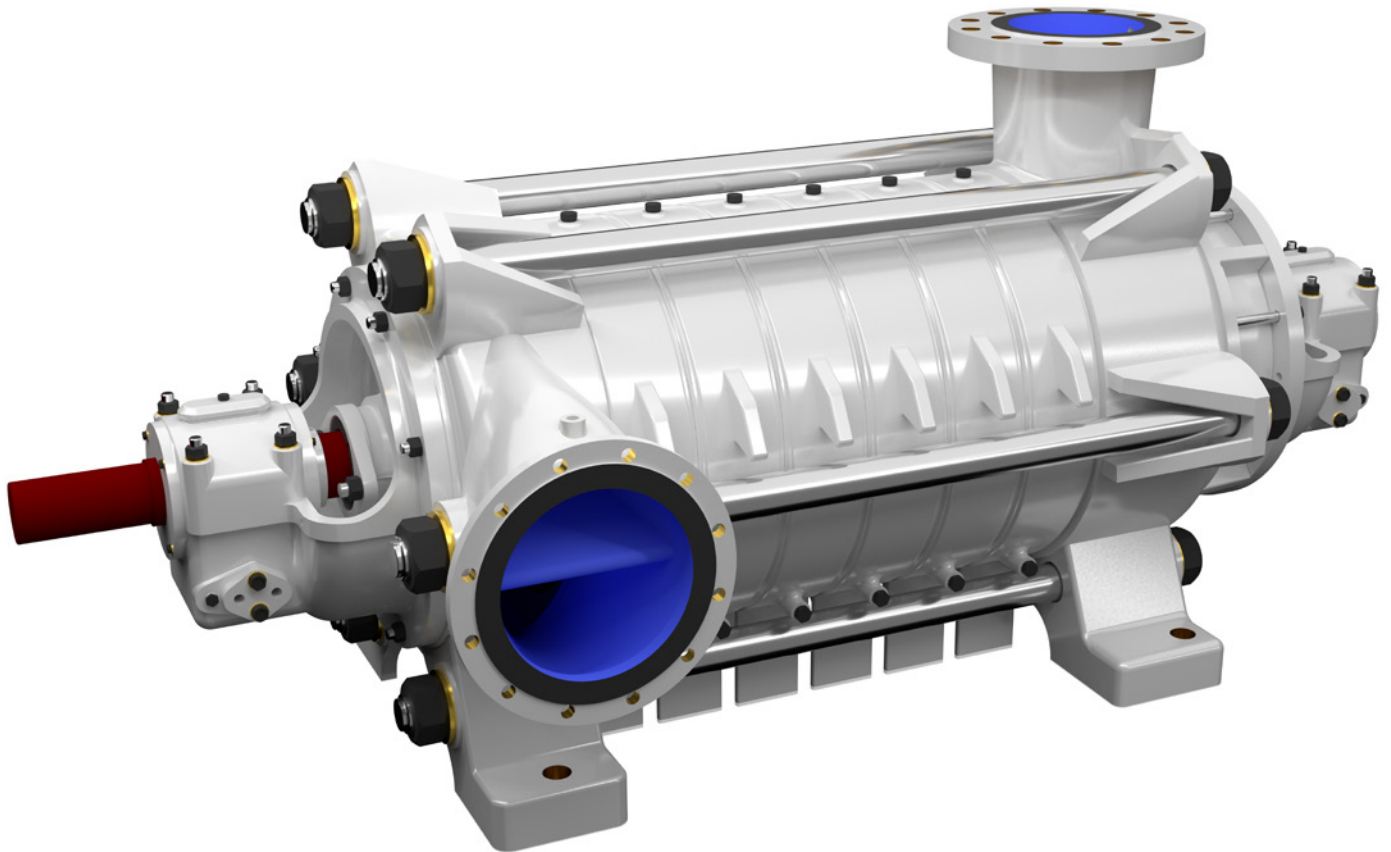

TYPICAL APPLICATIONS

- pumping of pure or mechanically contaminated water with solids with the grain size of up to 2 mm,
- pressure boosting,
- technological processes,
- industrial systems,
- coal, copper, salt and other mines,
- mining – main and auxiliary dewatering.

KEY ADVANTAGES

- long life ensured by the use of state-of-the-art corrosion and erosion resistant materials (salt-resistant workmanship),
- special material execution DUPLEX especially resistant to difficult conditions,
- possibility to use an electronic system of the balance disk wear monitoring,
- connection dimensions in compliance with multi-stage drainage pumps,
- approved for operation in explosion-hazard zones – ATEX Ex I M2.

PUMP PERFORMANCE CURVE

WPW-100

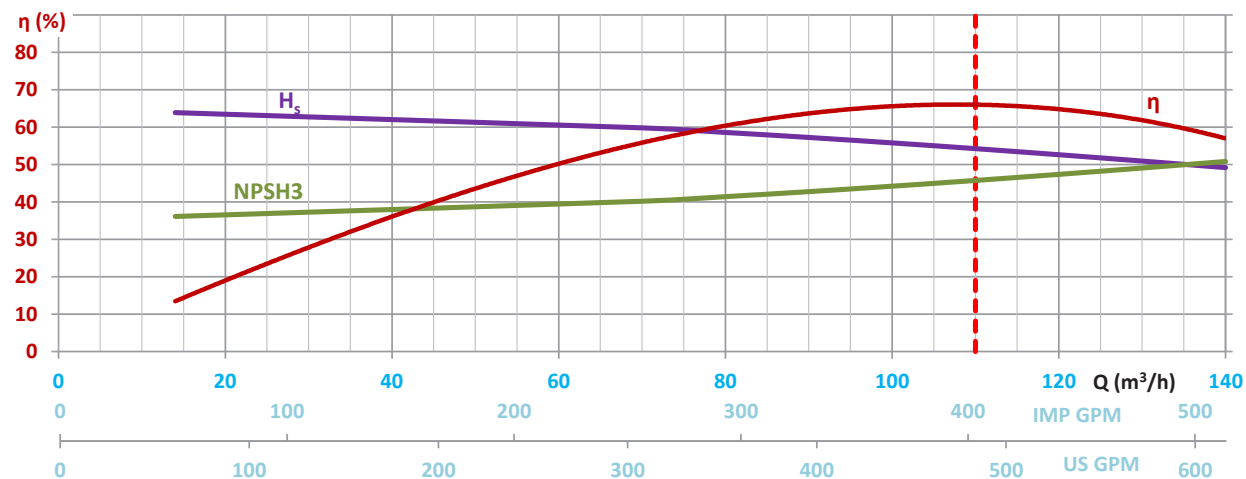
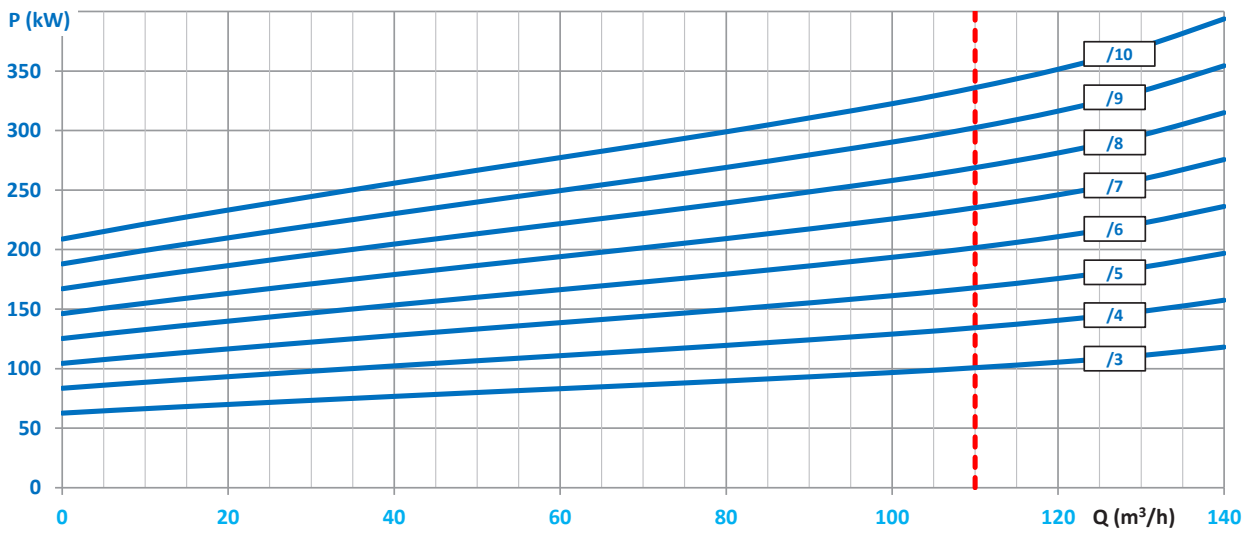
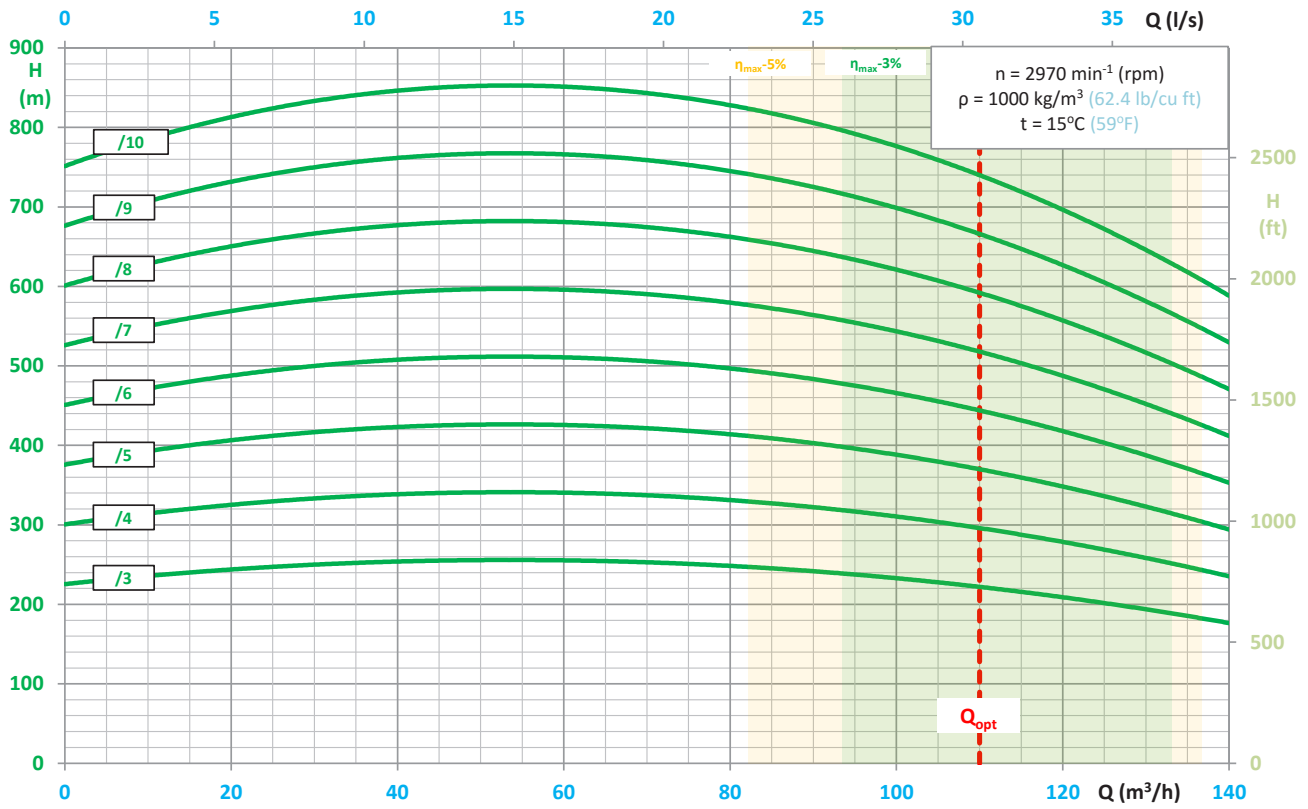

$H_s, NPSH_3$	(m) (ft)
8	26.2
7	23.0
6	19.7
5	16.4
4	13.1
3	9.8
2	6.6
1	3.3
0	0

WPW-150

PUMP PERFORMANCE CURVE

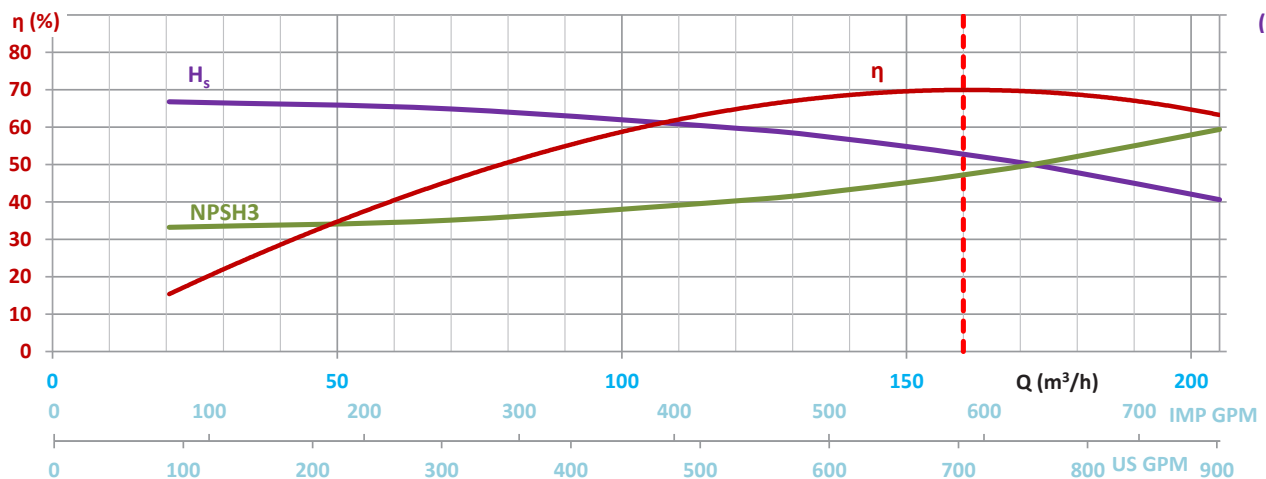
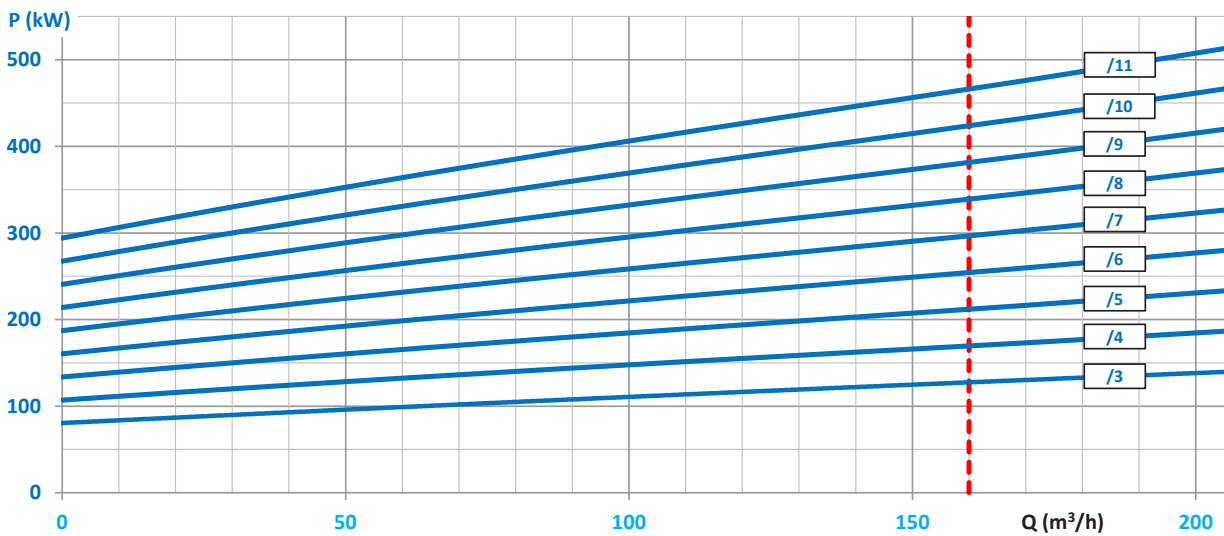
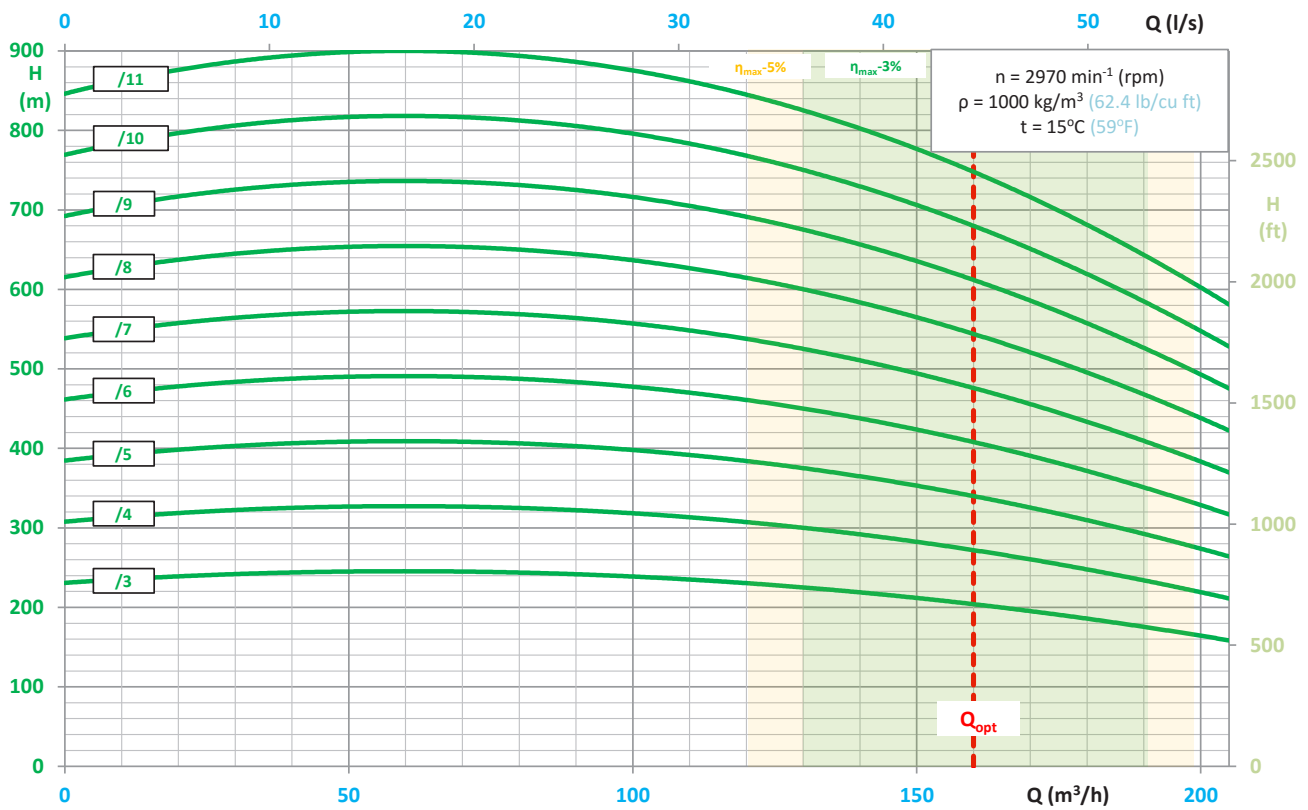

PUMP PERFORMANCE CURVE

WPW-200

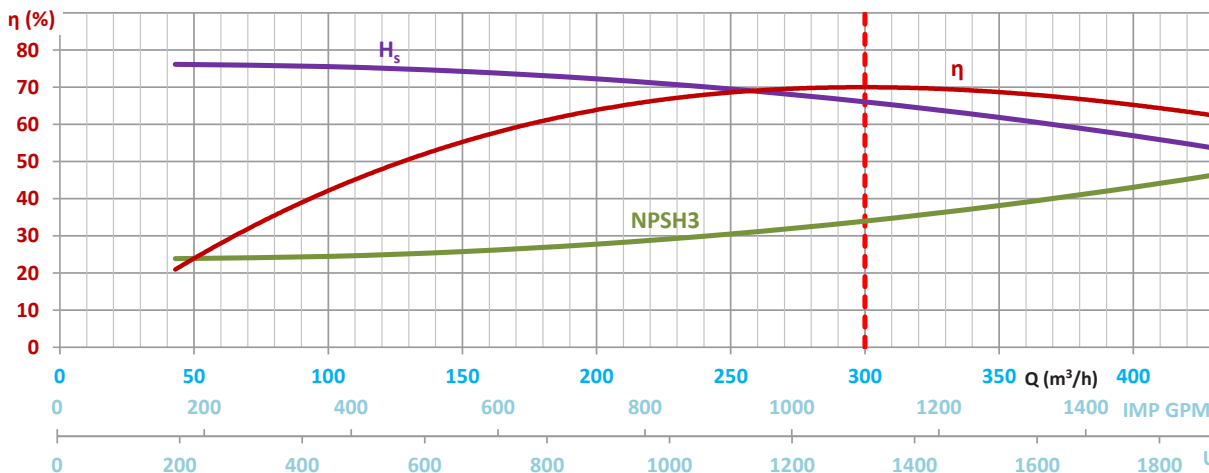
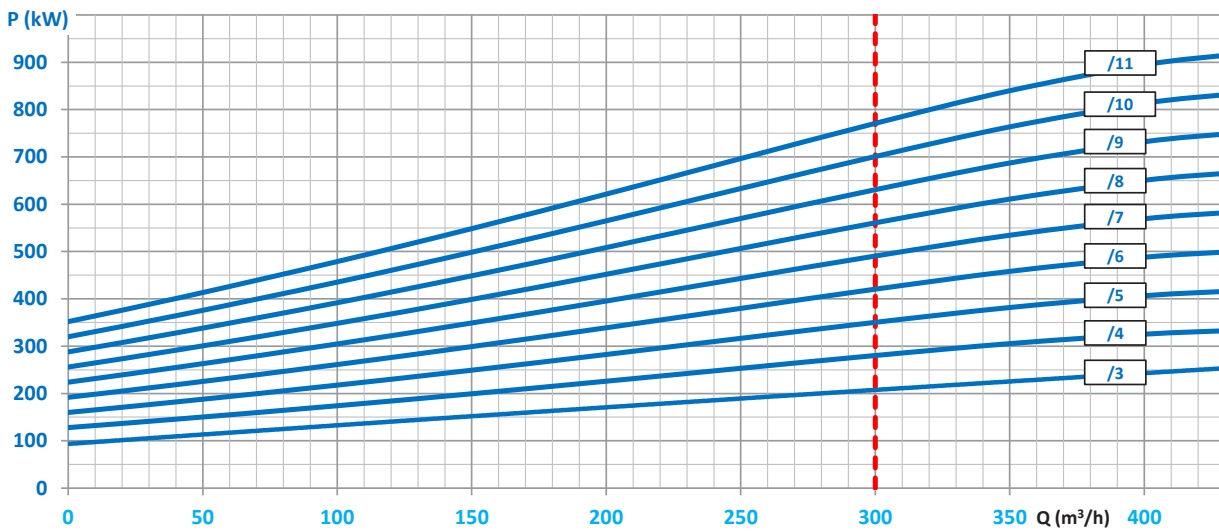
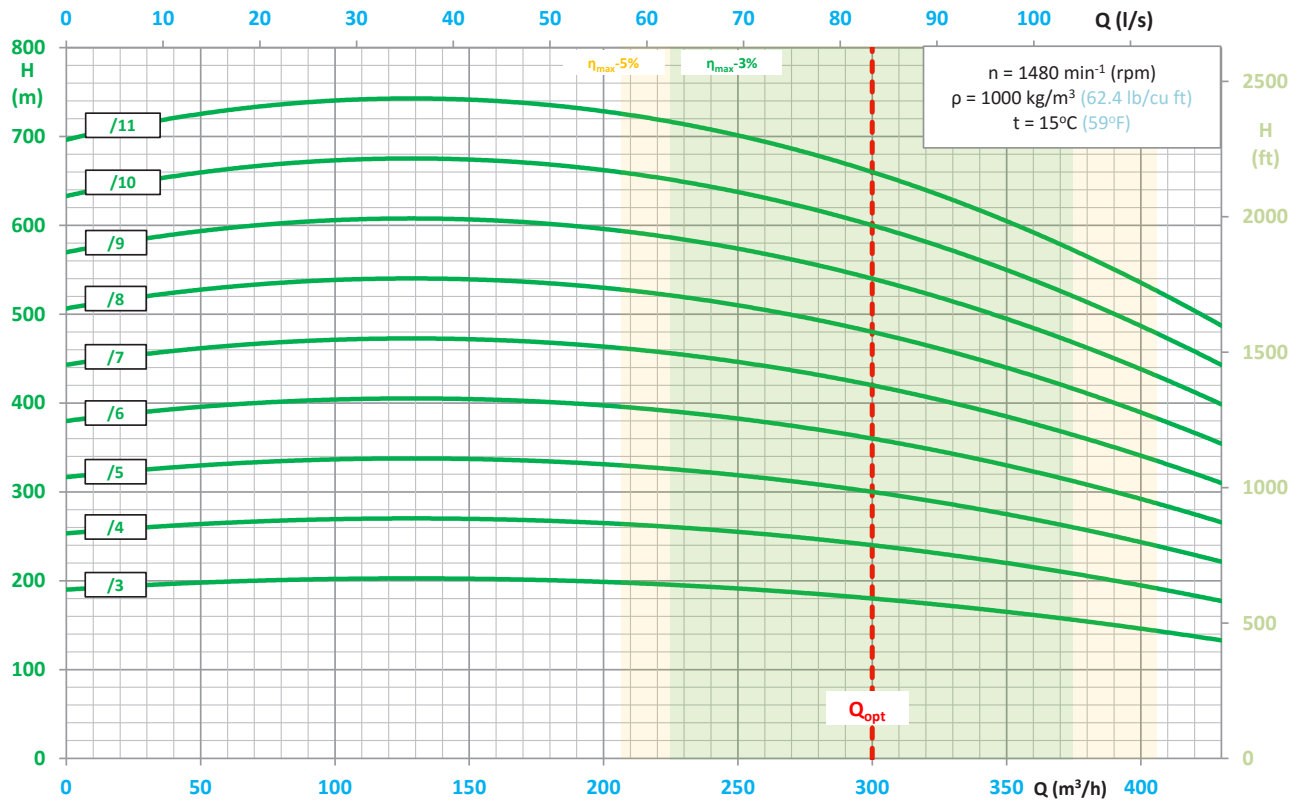

H_s , NPSH3	(m)	(ft)
8	26.2	
7	23.0	
6	19.7	
5	16.4	
4	13.1	
3	9.8	
2	6.6	
1	3.3	
0	0	

WPW-250

PUMP PERFORMANCE CURVE

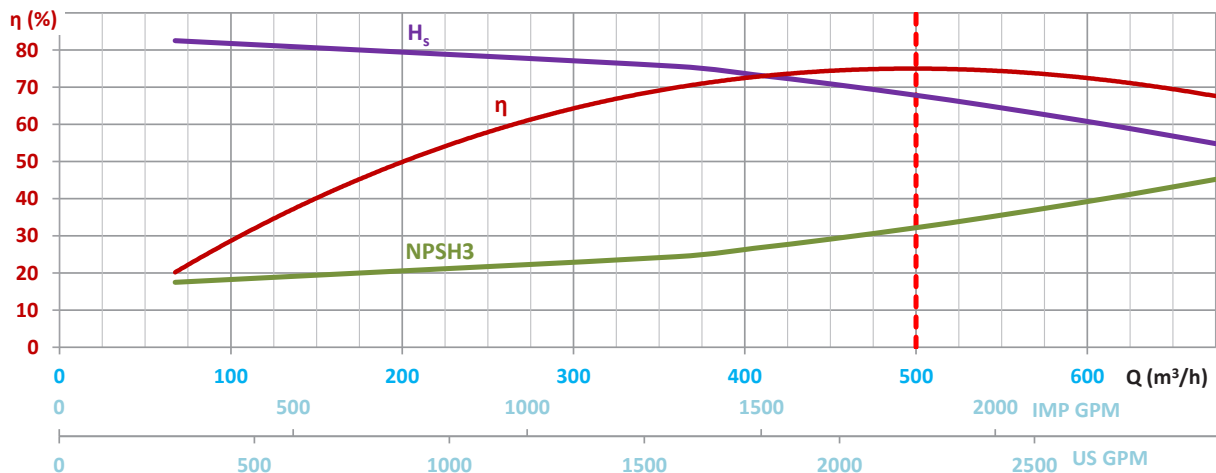
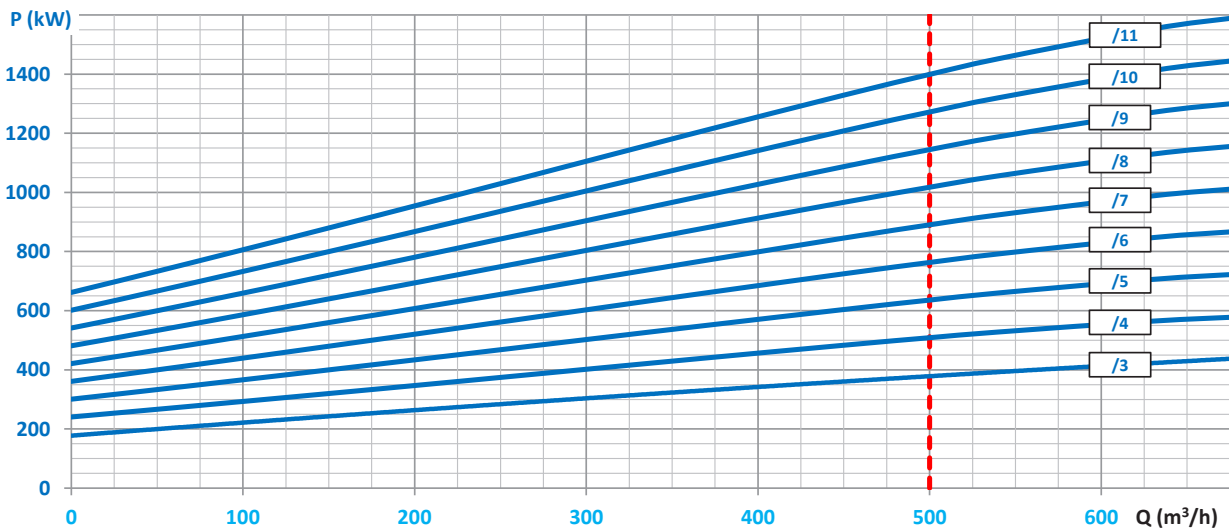
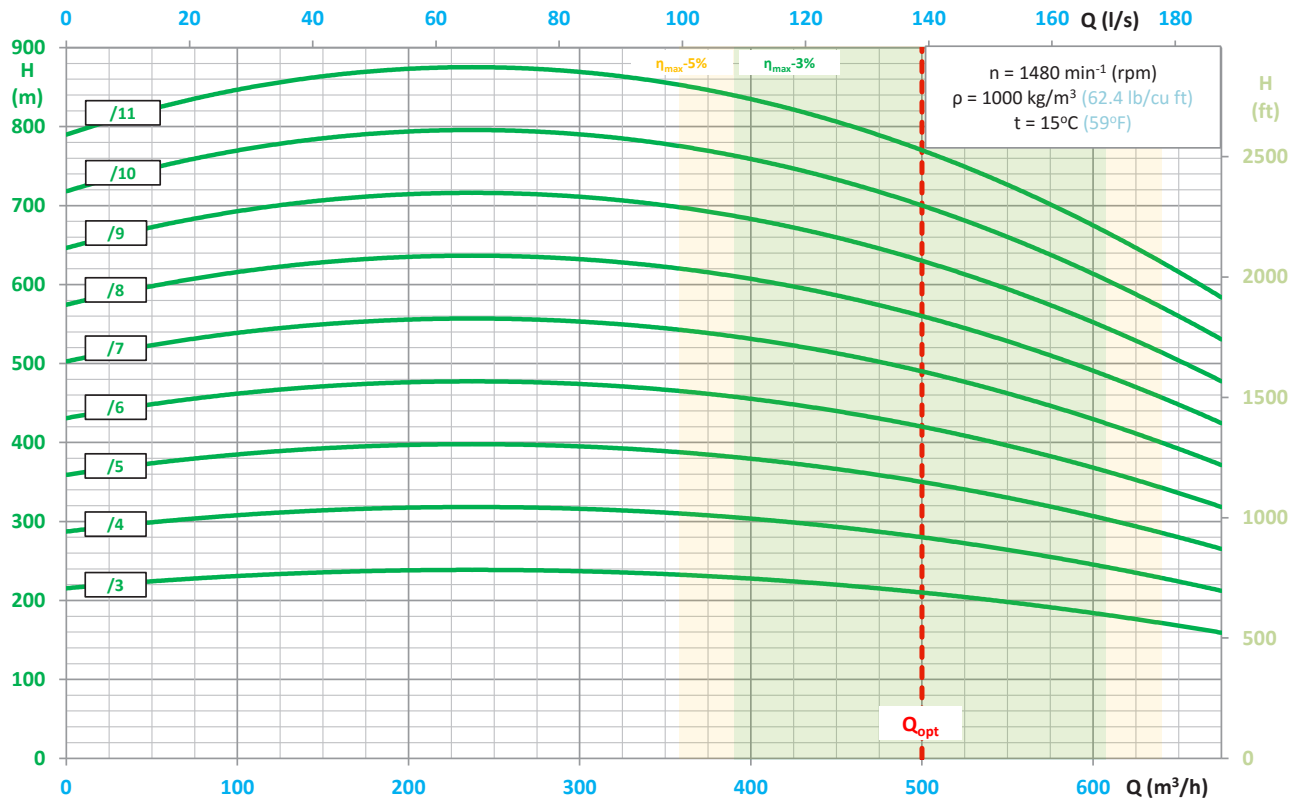

H _s , NPSH3	(m)	(ft)
8	26.2	
7	23.0	
6	19.7	
5	16.4	
4	13.1	
3	9.8	
2	6.6	
1	3.3	
0	0	

PUMP PERFORMANCE CURVE

WPW-300

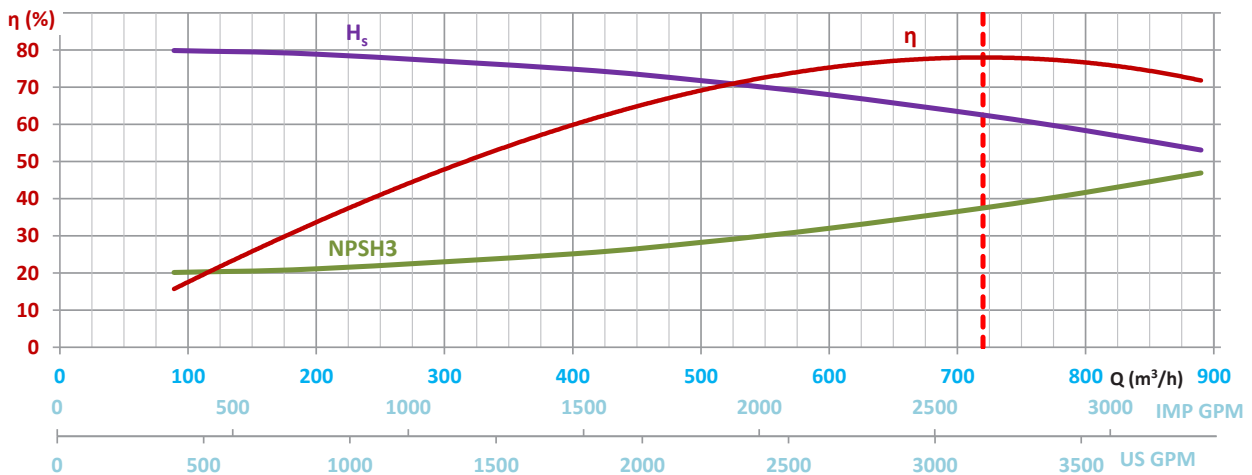
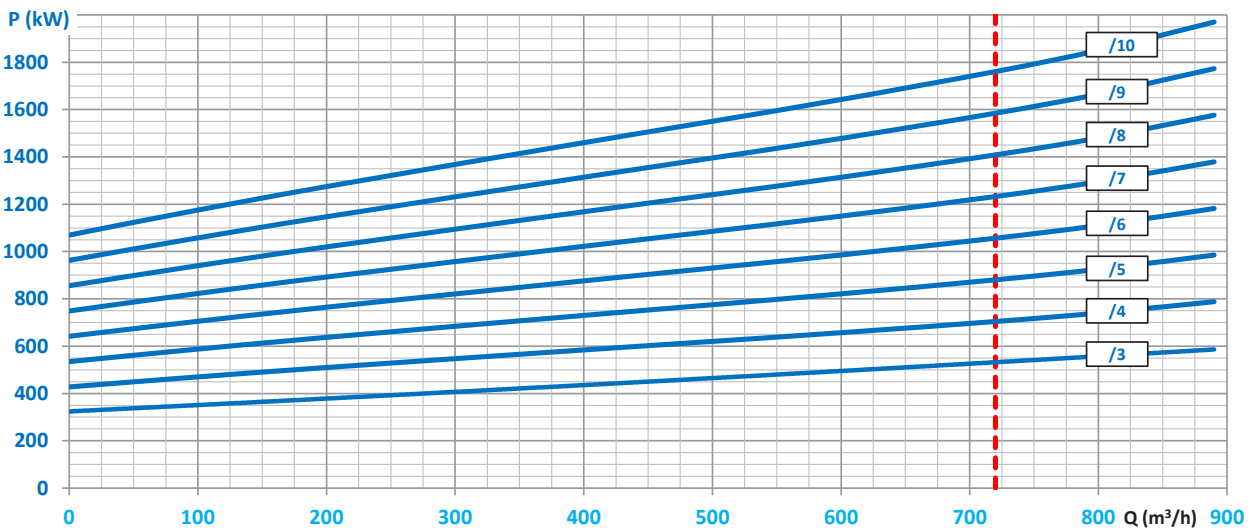
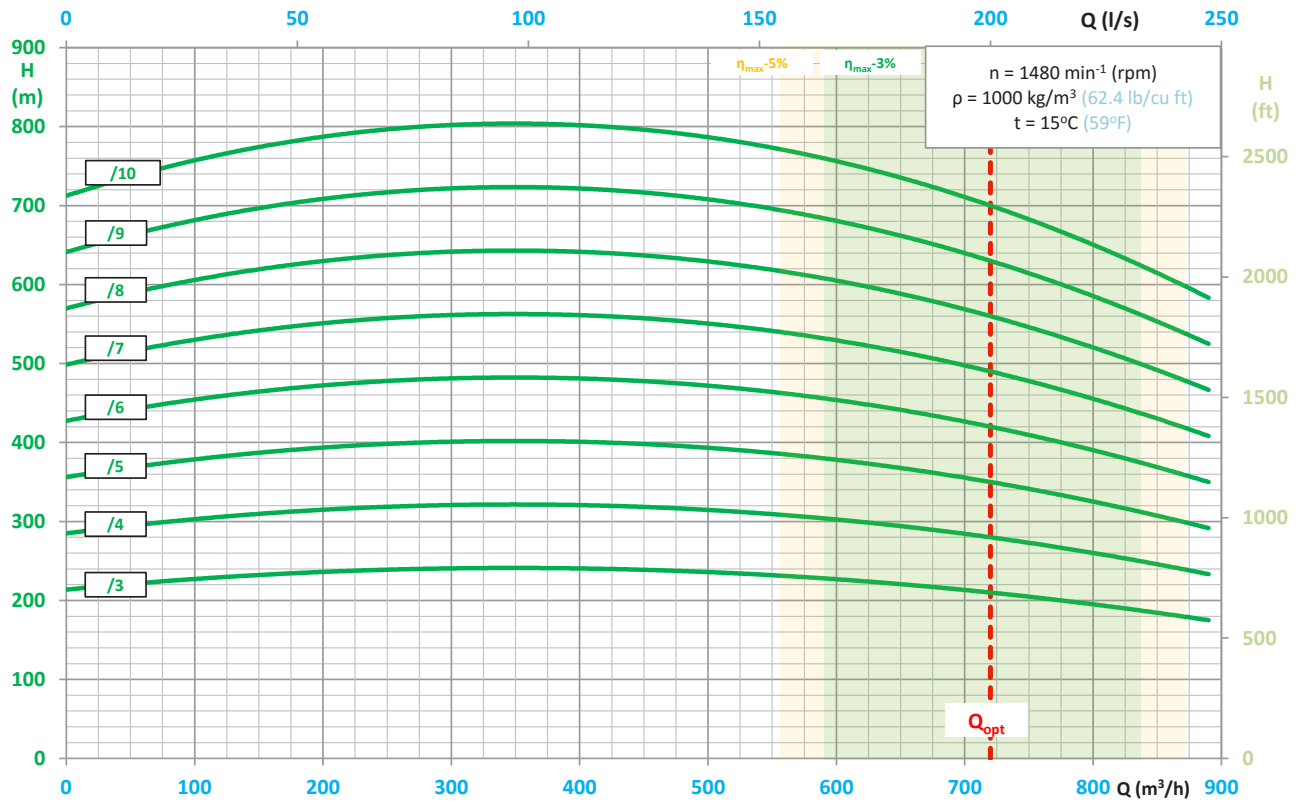

H_s , NPSH3 (m)	(ft)
8	26.2
7	23.0
6	19.7
5	16.4
4	13.1
3	9.8
2	6.6
1	3.3
0	0

HIGH PRESSURE IMPELLER PUMPS

Type BB4

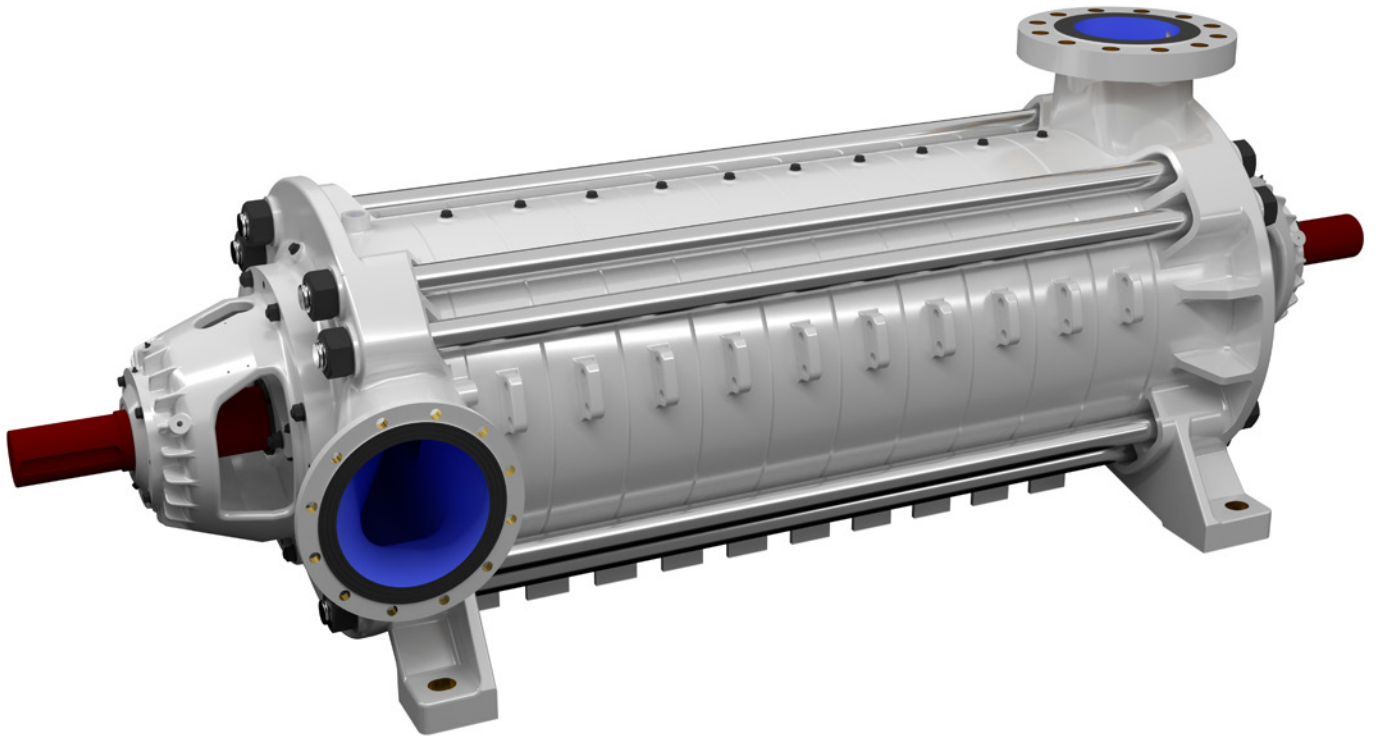

TYPICAL APPLICATIONS

- pumping of pure or mechanically contaminated water with solids with the grain size of up to 2 mm,
- pressure boosting,
- technological processes,
- industrial systems,
- coal, copper, salt and other mines,
- mining – main and auxiliary dewatering.

KEY ADVANTAGES

- new design with high efficiency
- long life ensured by the use of state-of-the-art corrosion and erosion resistant materials (salt-resistant workmanship),
- special material execution DUPLEX especially resistant to difficult conditions,
- possibility to use an electronic system of the balance disk wear monitoring,
- approved for operation in explosion-hazard zones – ATEX Ex I M2.

PUMP PERFORMANCE CURVE

WE-250

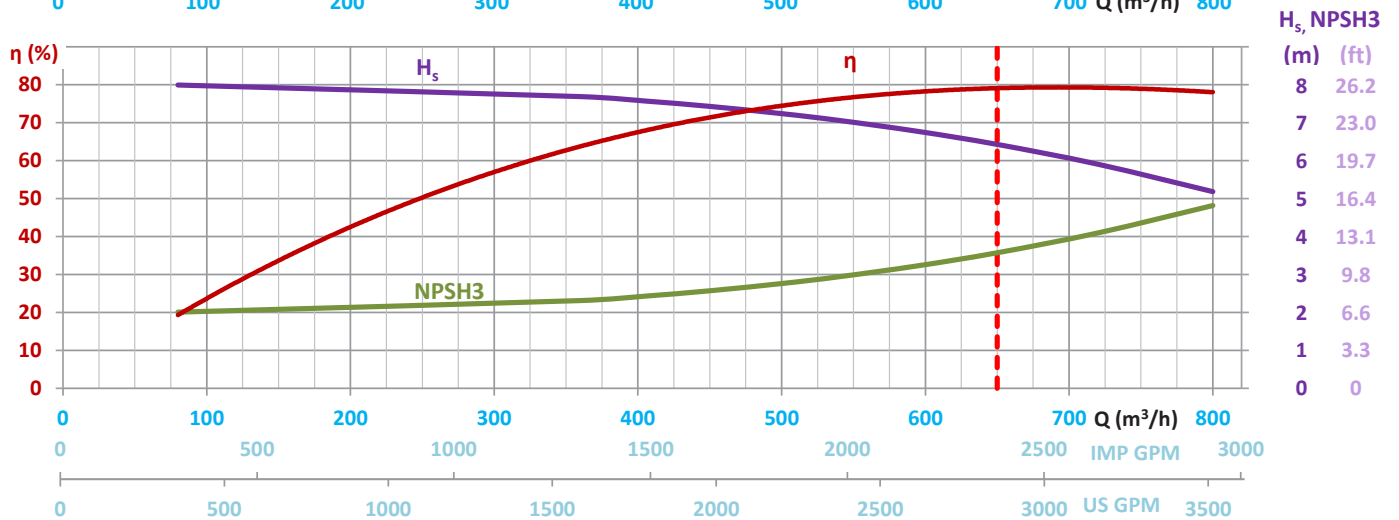
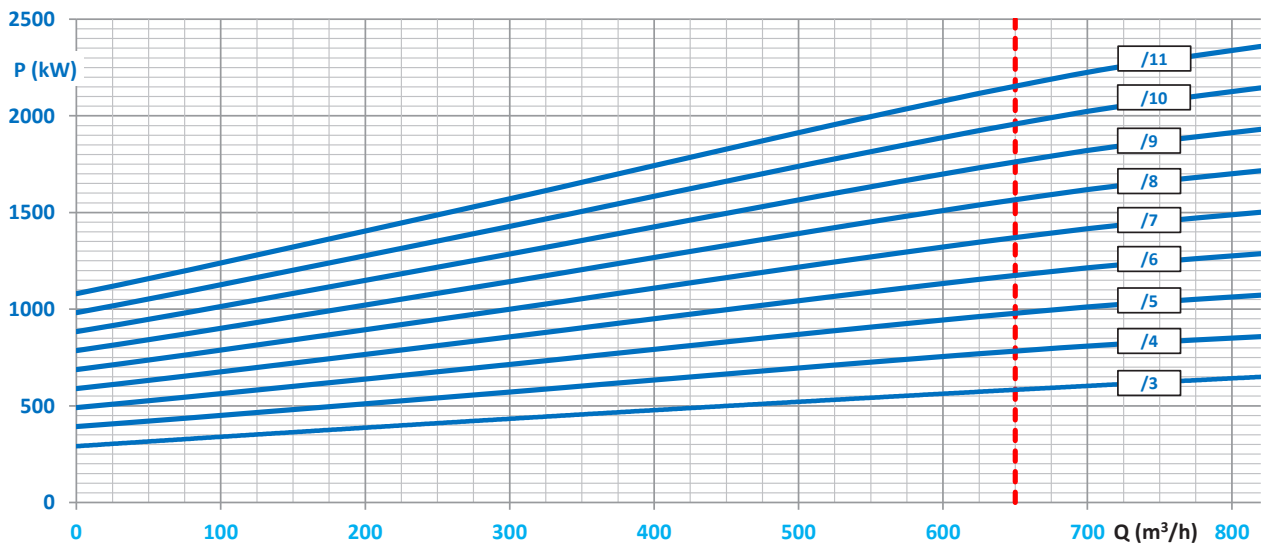
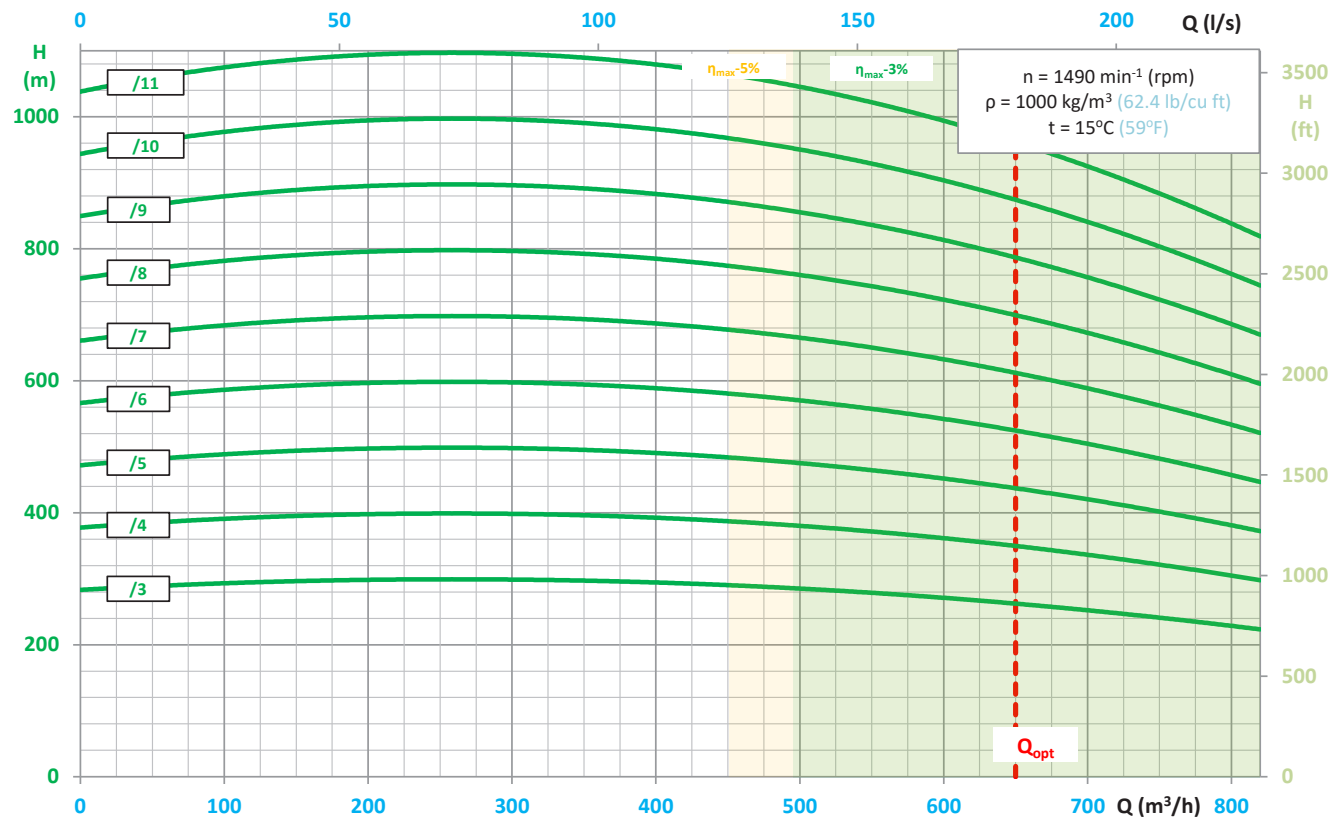

HIGH PRESSURE IMPELLER PUMPS

Type BB4

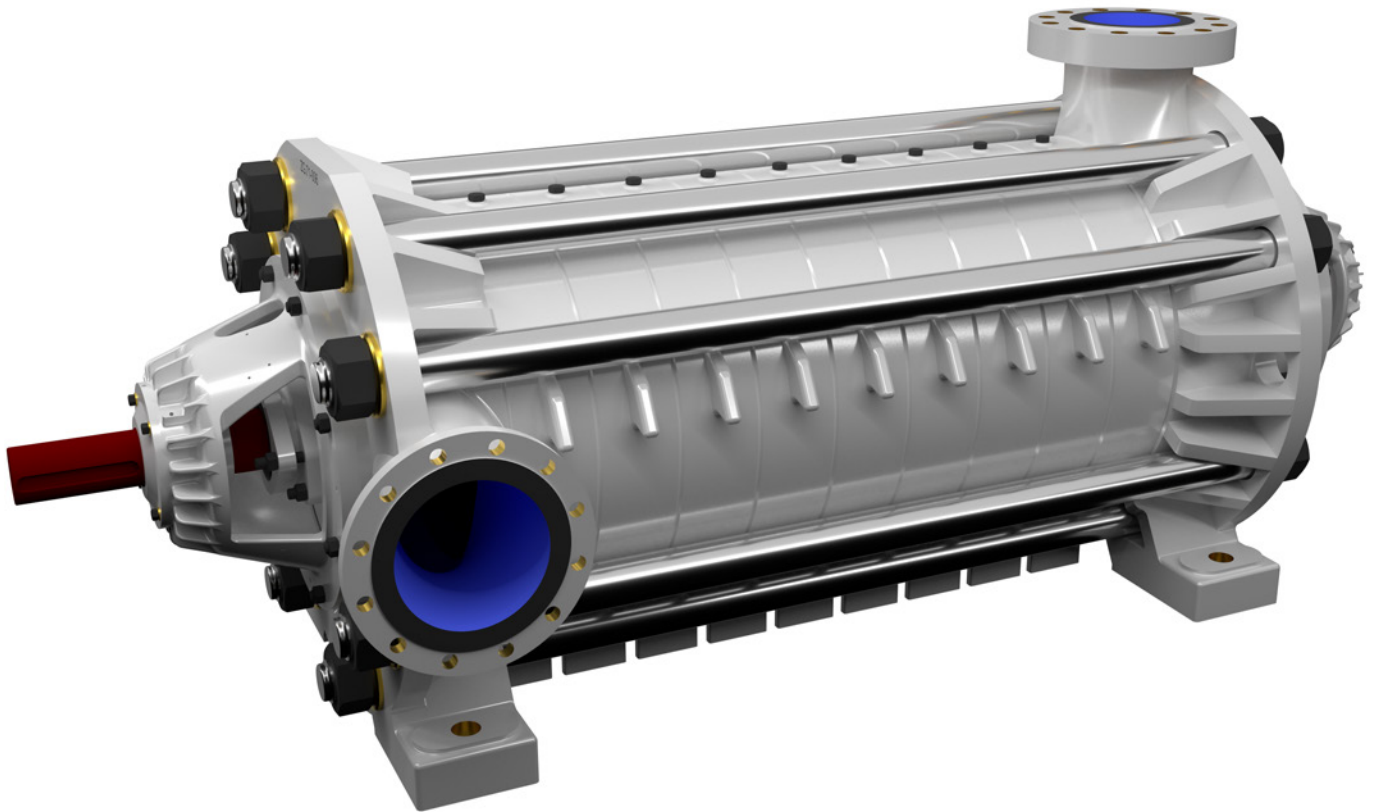

TYPICAL APPLICATIONS

- pumping of pure or mechanically contaminated water with solids with the grain size of up to 2 mm,
- pressure boosting,
- technological processes,
- industrial systems,
- coal, copper, salt and other mines,
- mining – main and auxiliary dewatering.

KEY ADVANTAGES

- long life ensured by the use of state-of-the-art corrosion and erosion resistant materials (salt-resistant workmanship),
- special material execution DUPLEX especially resistant to difficult conditions,
- possibility to use an electronic system of the balance disk wear monitoring,
- connection dimensions in compliance with multi-stage drainage pumps,
- approved for operation in explosion-hazard zones – ATEX Ex I M2.

PUMP PERFORMANCE CURVE

WPWH-200

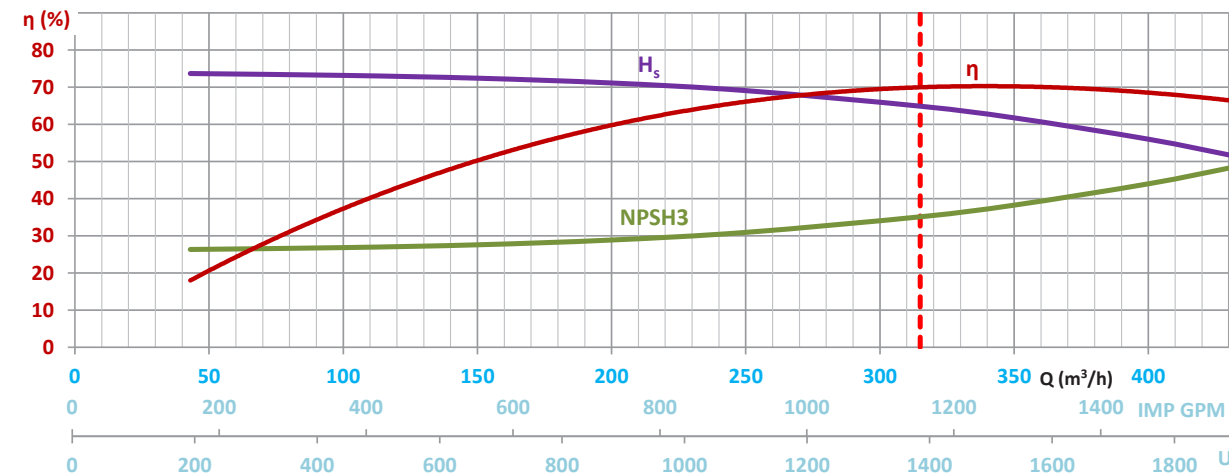
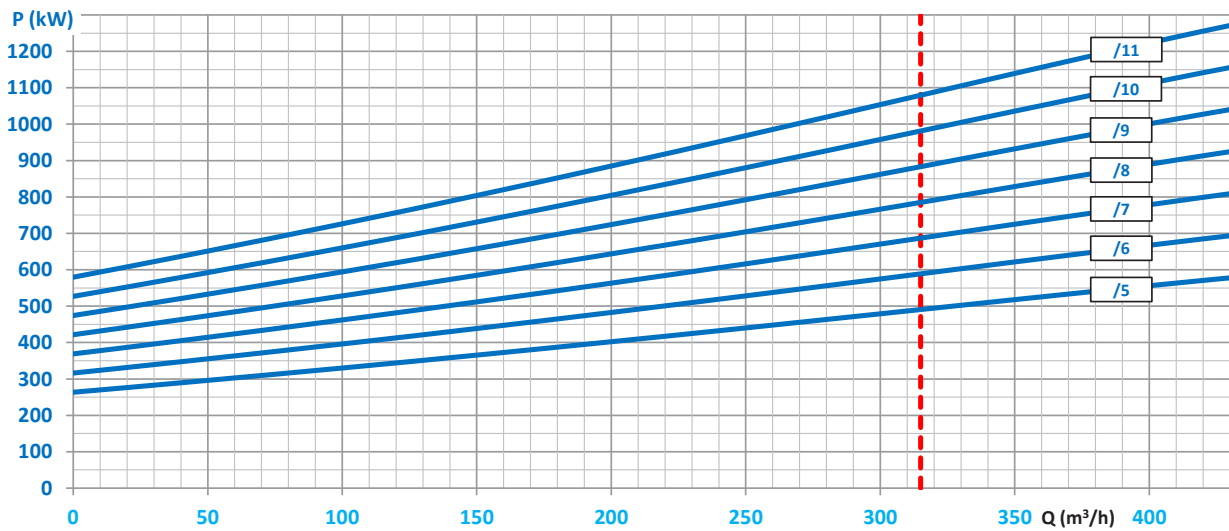
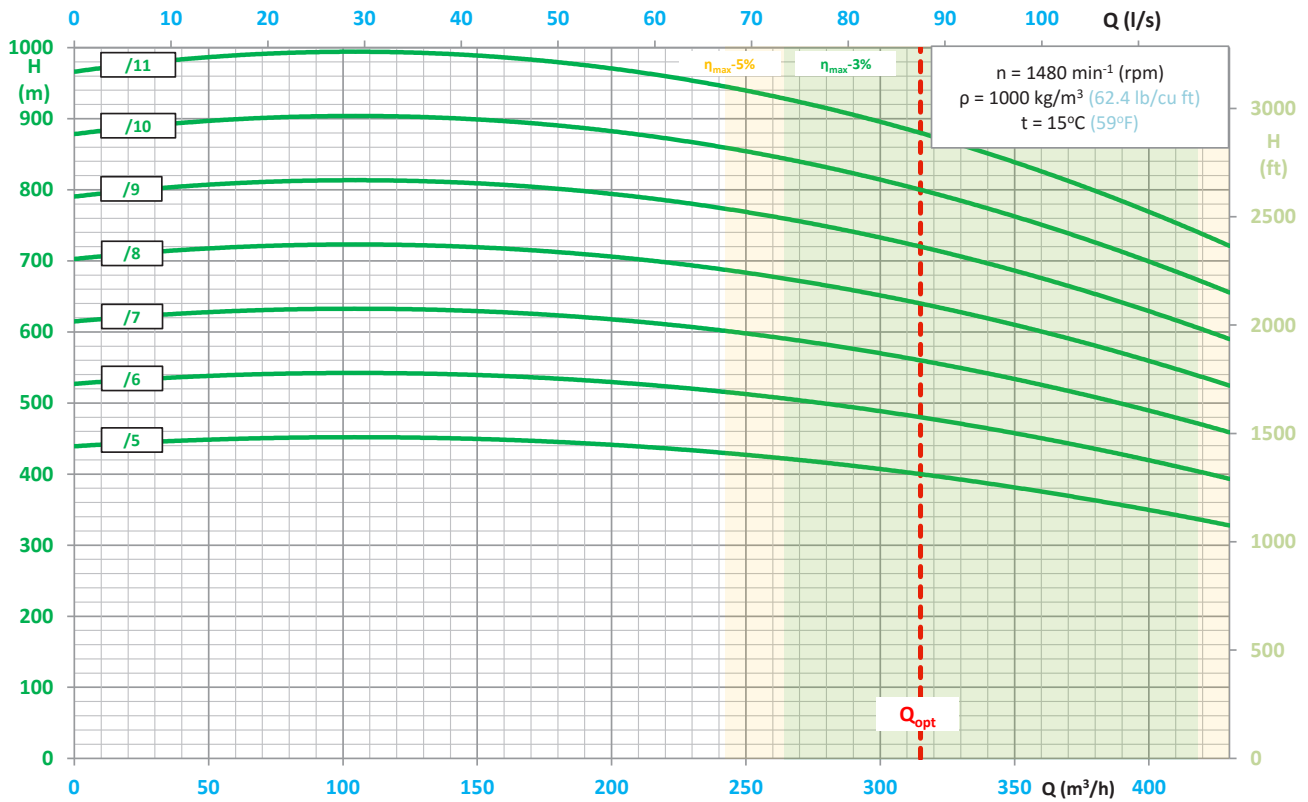

WPWH-250

PUMP PERFORMANCE CURVE

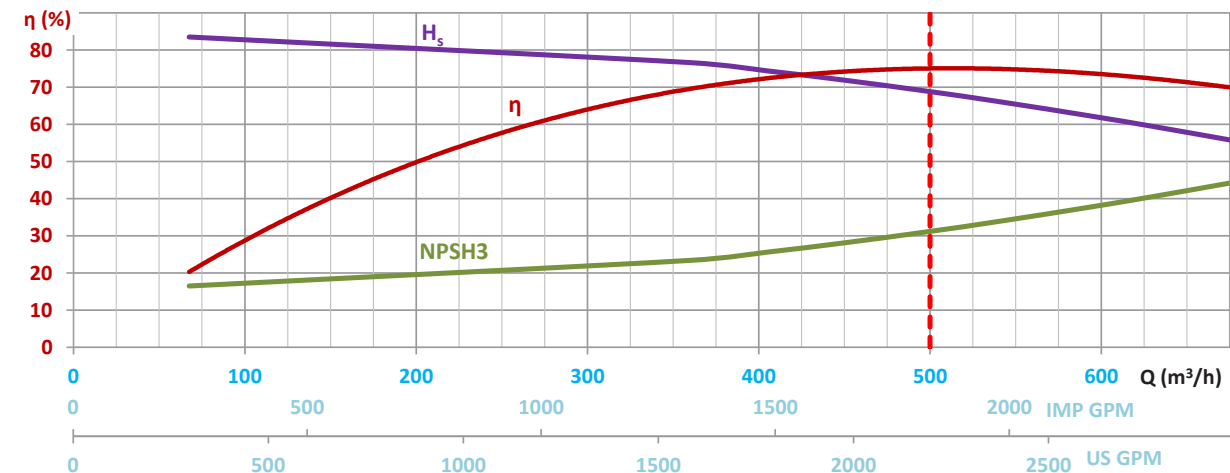
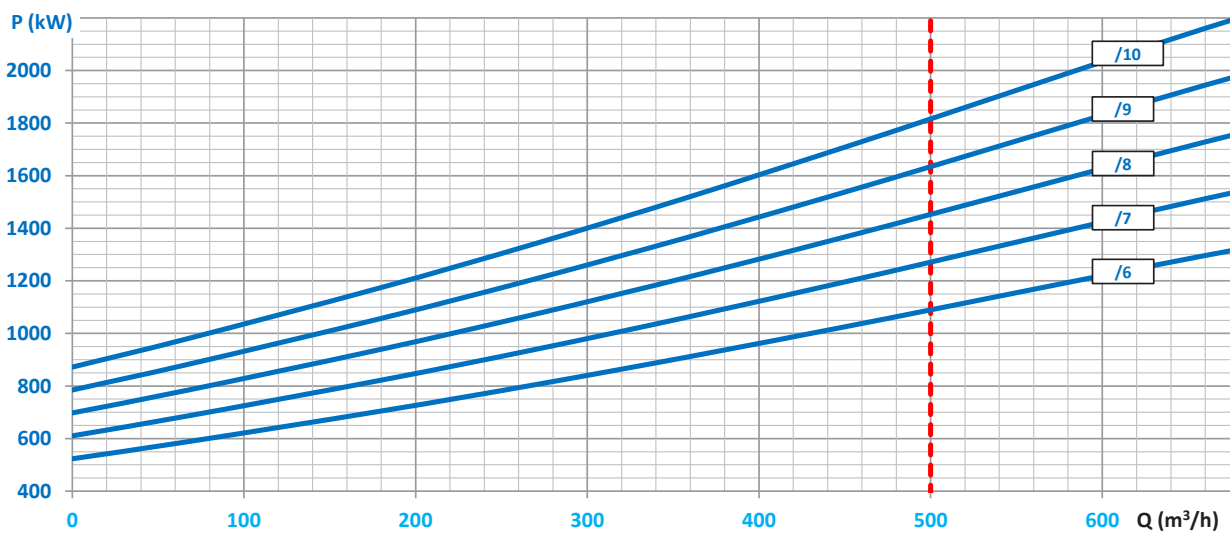
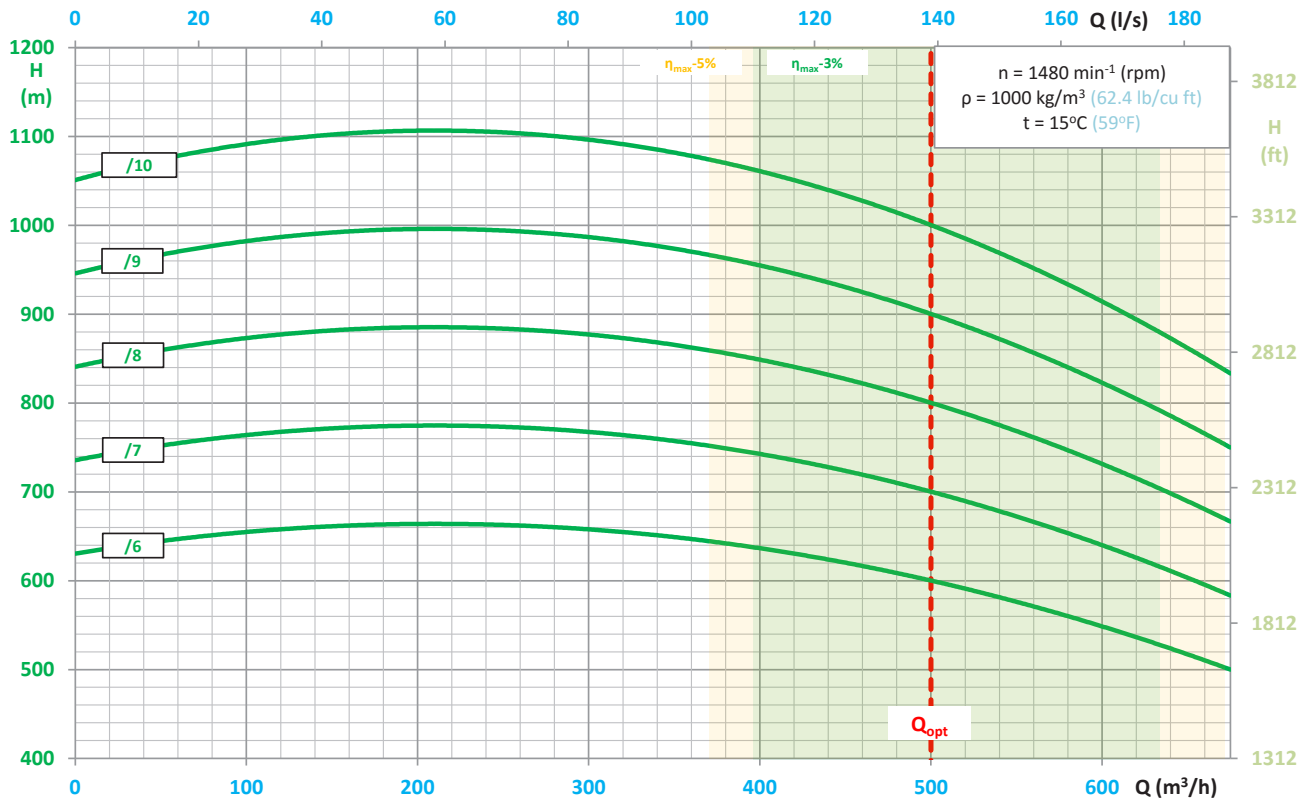

H_s , NPSH3 (m)	(ft)
8	26.2
7	23.0
6	19.7
5	16.4
4	13.1
3	9.8
2	6.6
1	3.3
0	0

Engineering company

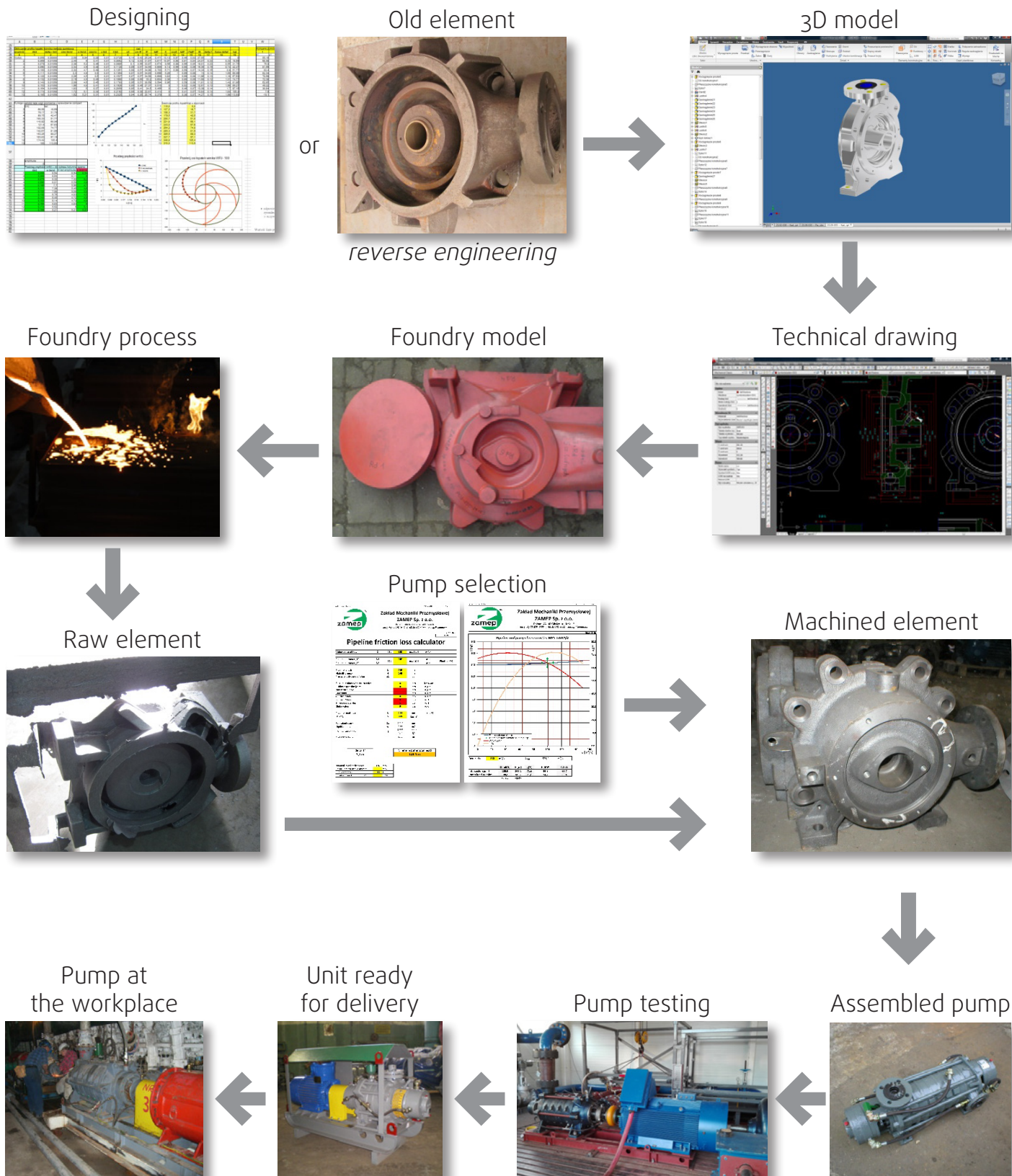

Repairs

IMPELLER PUMP REPAIRS

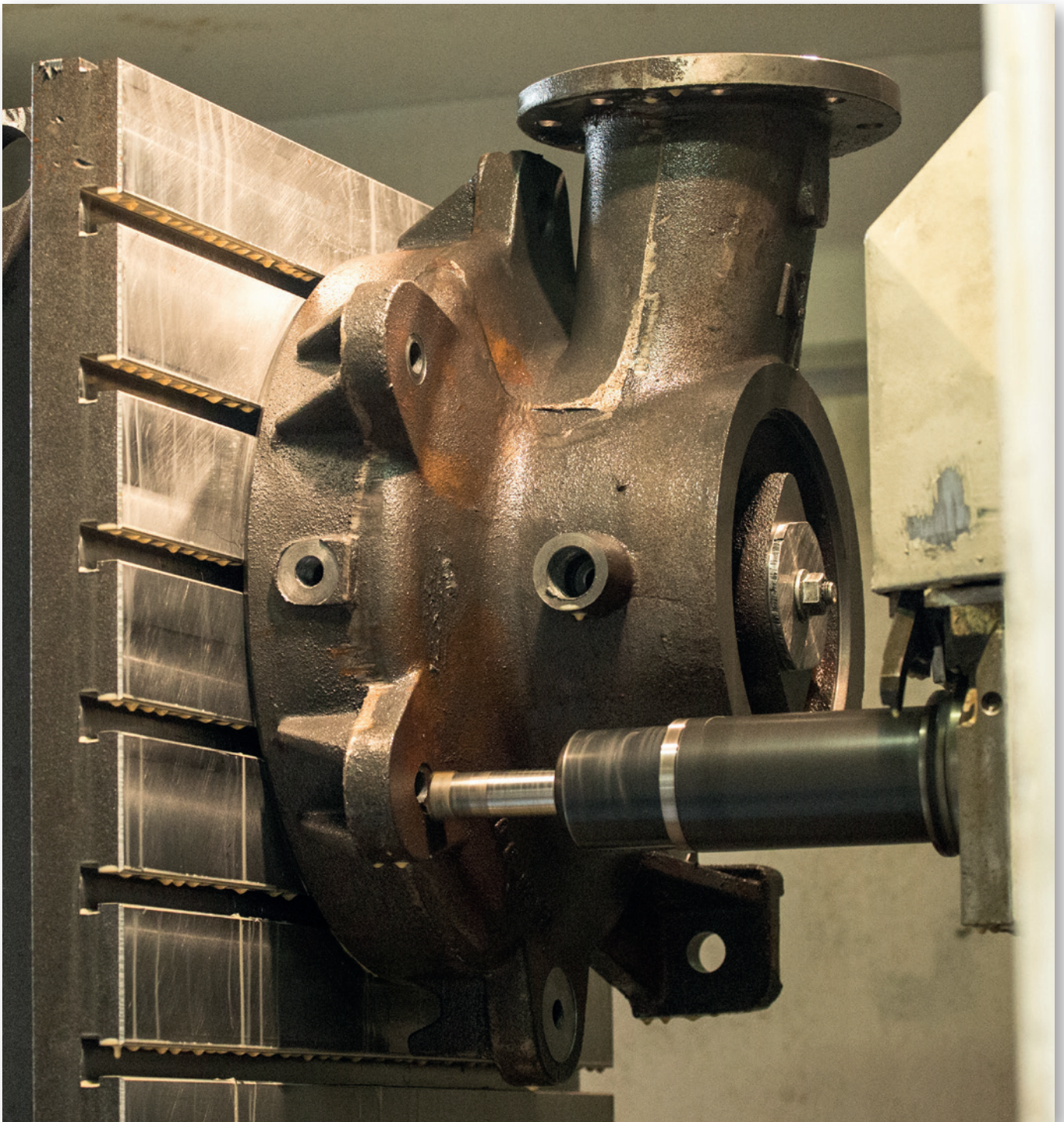

WE OFFER EXECUTION OF REPAIRS OF IMPELLER PUMPS MADE BY THE FOLLOWING MANUFACTURERS:

- ZMP „ZAMEP” Sp. z o.o.
- Sigma Pumpy Hranice s.r.o.
- CH Warman Pump Group
- POWEN S.A.
- Dichtung Pumpen Maschinenfabrik GmbH & Co. KG
- and others.

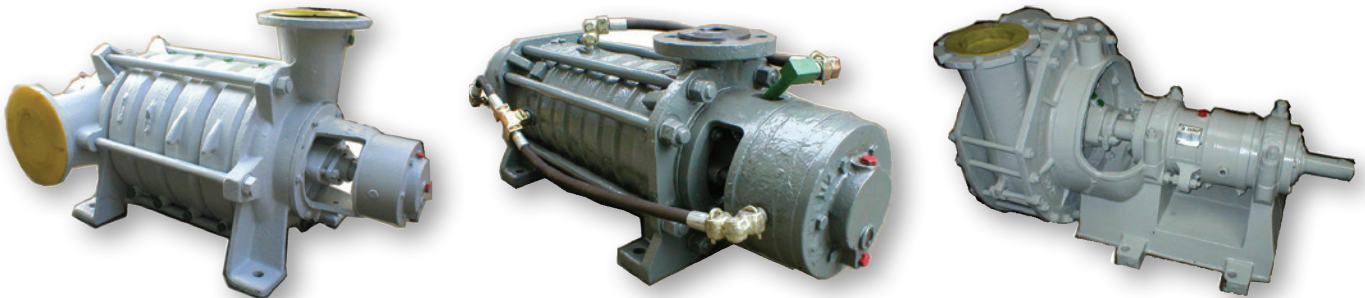

REPAIRS ON OUR OFFER:

- current, medium and major repairs according to own or entrusted documentation,
- restoration repairs,
- regenerative repairs,
- modernisation works including among others changes in:
 - the number of stages,
 - material workmanship,
 - the sealing system,
 - the flow system, i.e. adjustment to required operation parameters.



The components of pumps under repair are subject to hydrostatic tests and, at the Customer's request, the operation parameters are measured in a fixed range of the pump delivery. The parameters are measured with accuracy class 1 or 2 according to PN-EN ISO 9906 on one of the test stands.

Foundry



OUR OFFER INCLUDES CASTING FROM OWN OR ENTRUSTED MOULDS

WE MAKE:

- Iron and alloy iron castings – up to 2000 kg (4400 lb)
- Cast and alloy cast steel castings – up to 2000 kg (4400 lb)
- Copper, bronze and brass castings – up to 2000 kg (4400 lb)
- DUPLEX, SUPER DUPLEX up to 2000 kg (4400 lb)

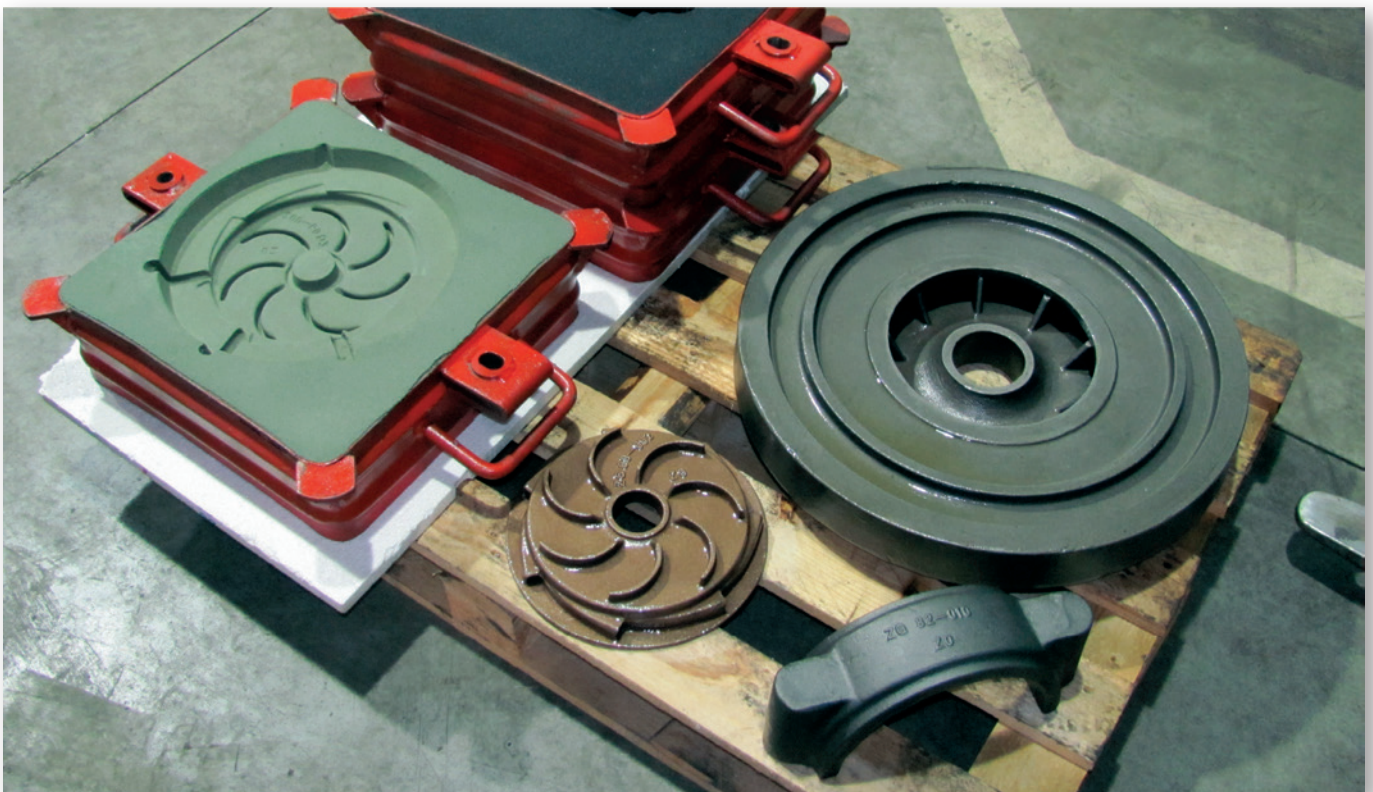
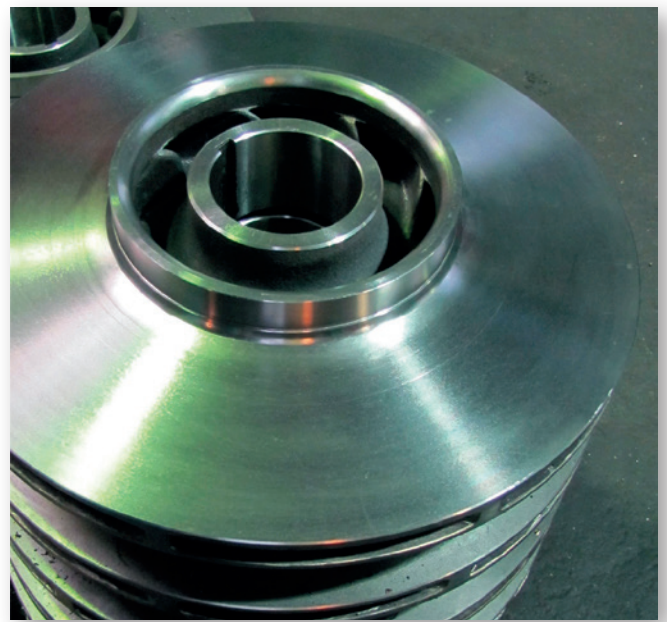

Units

PUMP UNITS

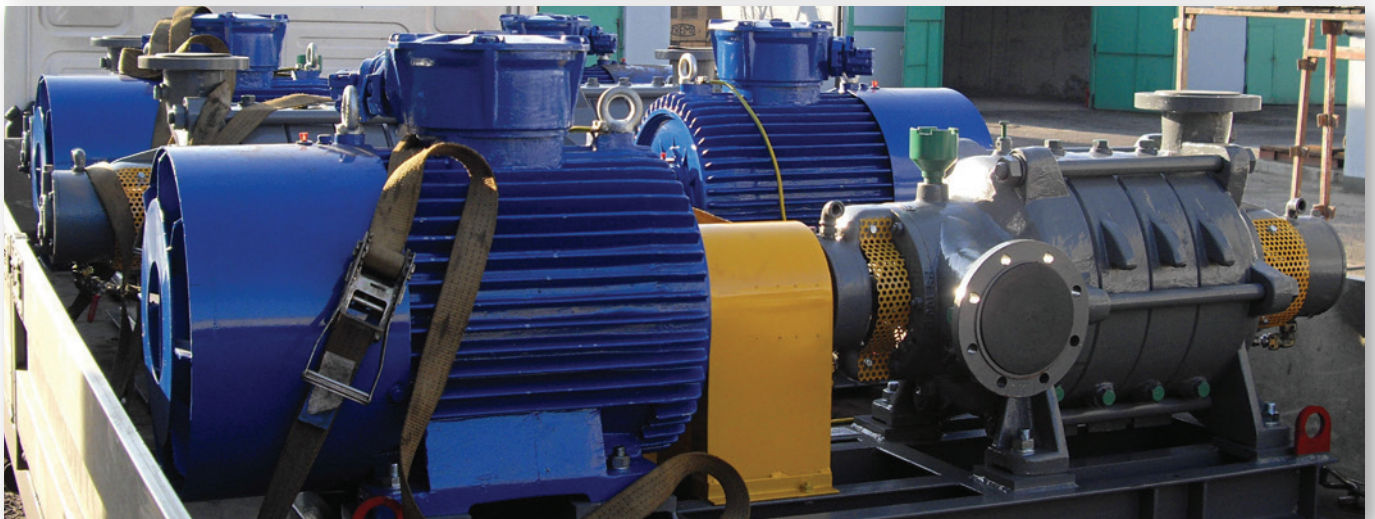
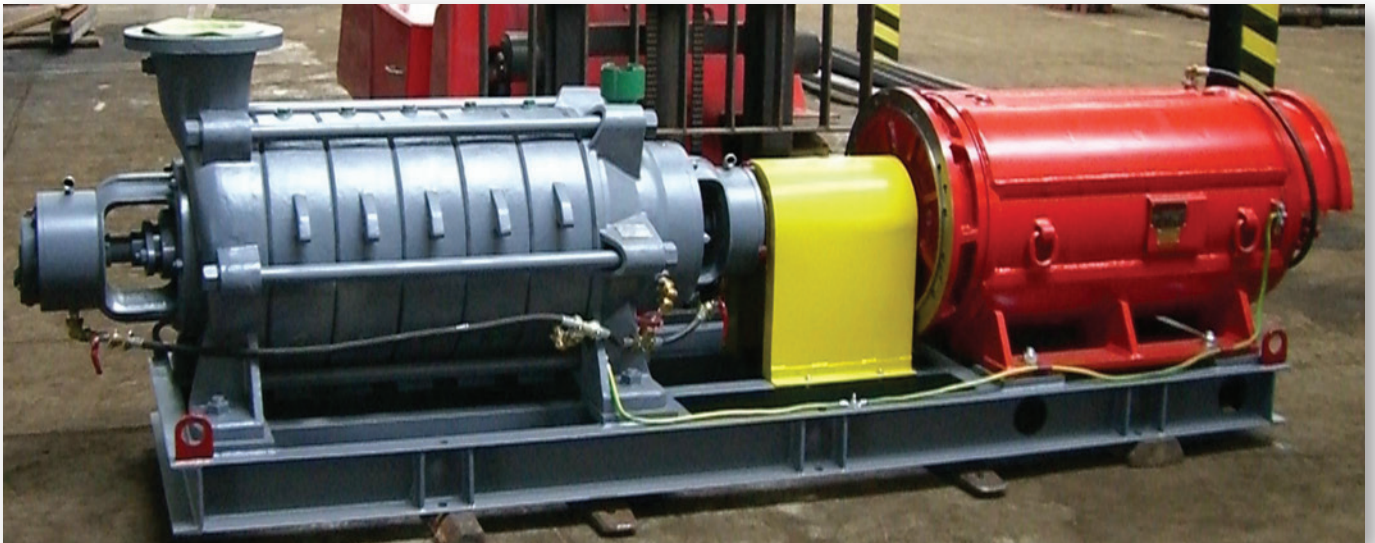
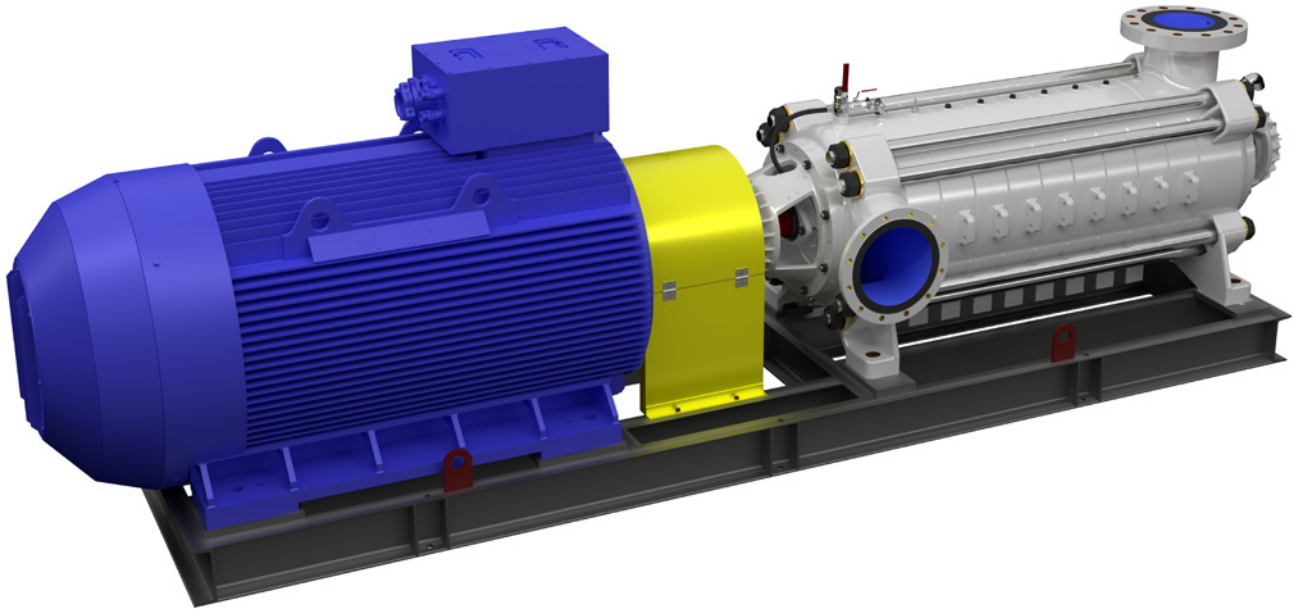

**FOR ALL PUMPS OFFERED BY ZAMEP, AS WELL AS
FOR REPAIRED PUMPS, OUR OFFER INCLUDES
PERFORMANCE OF COMPLETE PUMP UNITS**

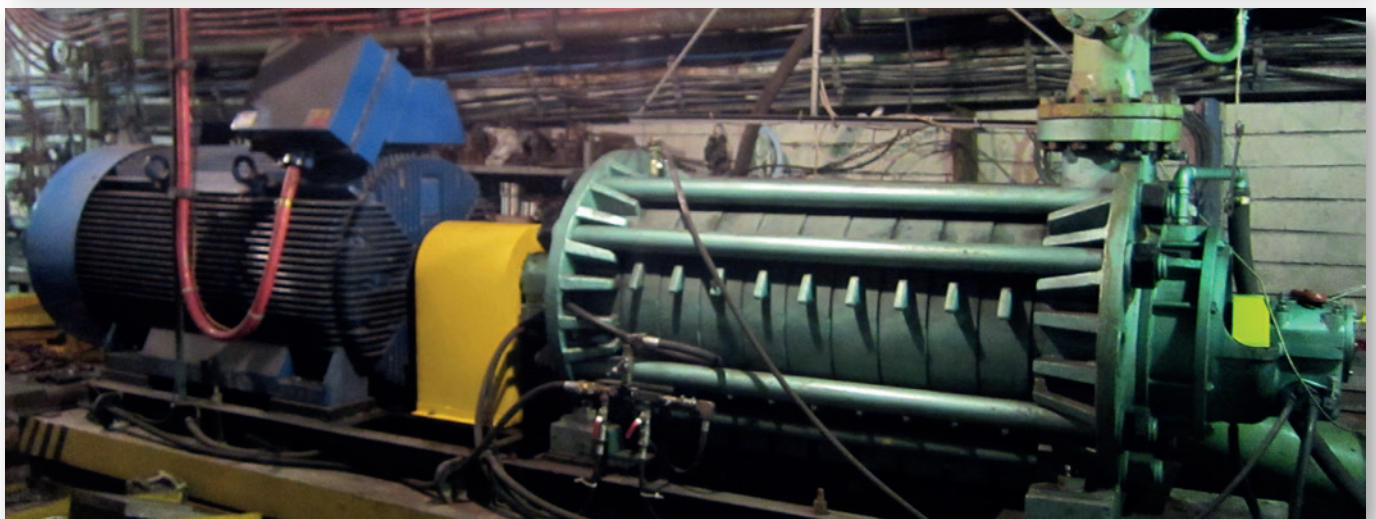
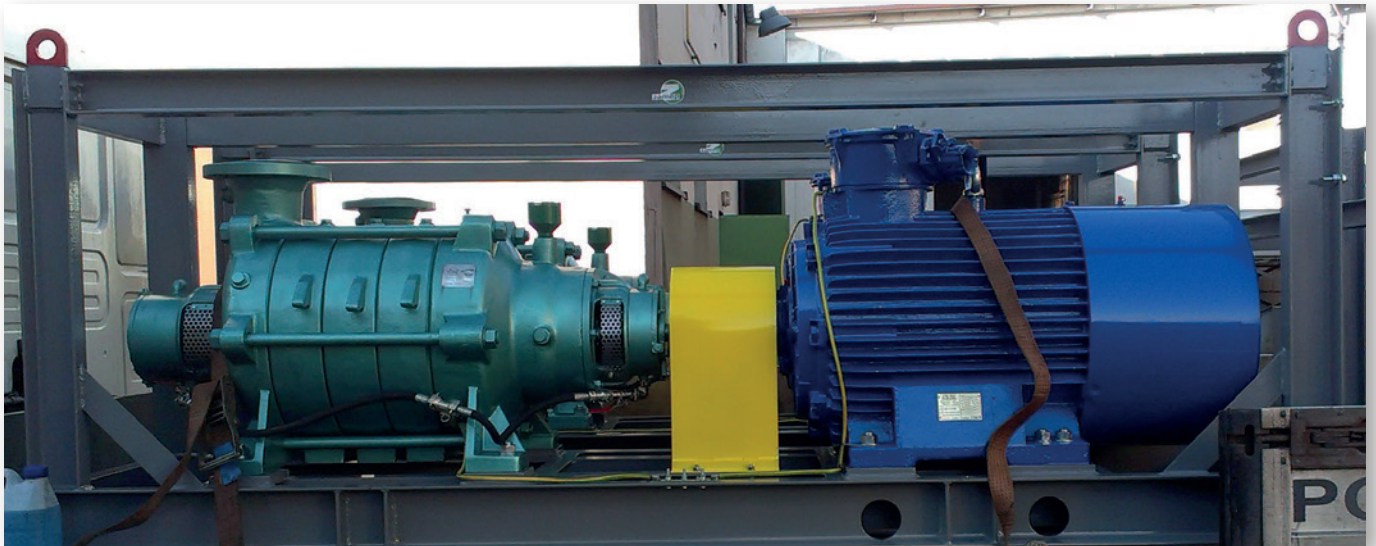

Notes



zamep

Certificates

Some of our certificates



This catalog does not constitute a sales offer as stipulated in the Civil Code.

© Copyright 2021 ZAMEP Sp. z o.o.

Zakład Mechaniki Przemysłowej ZAMEP Sp. z o.o.

44-100 Gliwice, ul. Udzieli 6, POLAND

tel. (+48) 32 279 10 90

tel./fax (+48) 32 279 11 90

e-mail: zamep@zamep.eu

www.zamep.eu

