

# WPWE-250\_20

Previous - WPWE-200

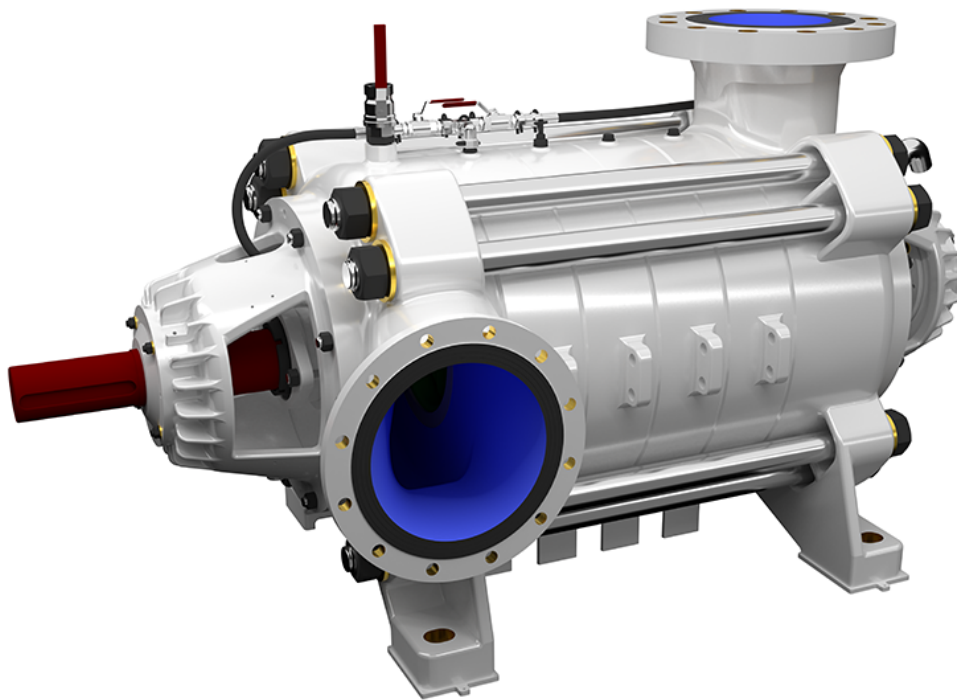

## MATERIAŁY DO POBRANIA



Katalog



2D



3D

---

ZAPISZ DO PDF / DRUKUJ STRONĘ

---

**DATA PUBLIKACJI - 2017-11-07**

# TYPICAL APPLICATIONS

- mining - main and auxiliary dewatering,
  - industrial systems,
  - technological processes,
  - pressure boosting,
  - pumping of pure or mechanically contaminated water with solids with the grain size of up to 2 mm,
  - coal, copper, salt mines and others.
- 

# KEY ADVANTAGES

- new improved design with increased efficiency
  - long life ensured by the use of state-of-the-art corrosion and erosion resistant materials (saltresistant workmanship),
  - special material execution DUPLEX especially resistant to difficult conditions,
  - possibility to use an electronic system of the balance disk wear monitoring,
  - approved for operation in explosion-hazard zones - ATEX Ex I M2.
- 

# PUMP PERFORMANCE CURVE

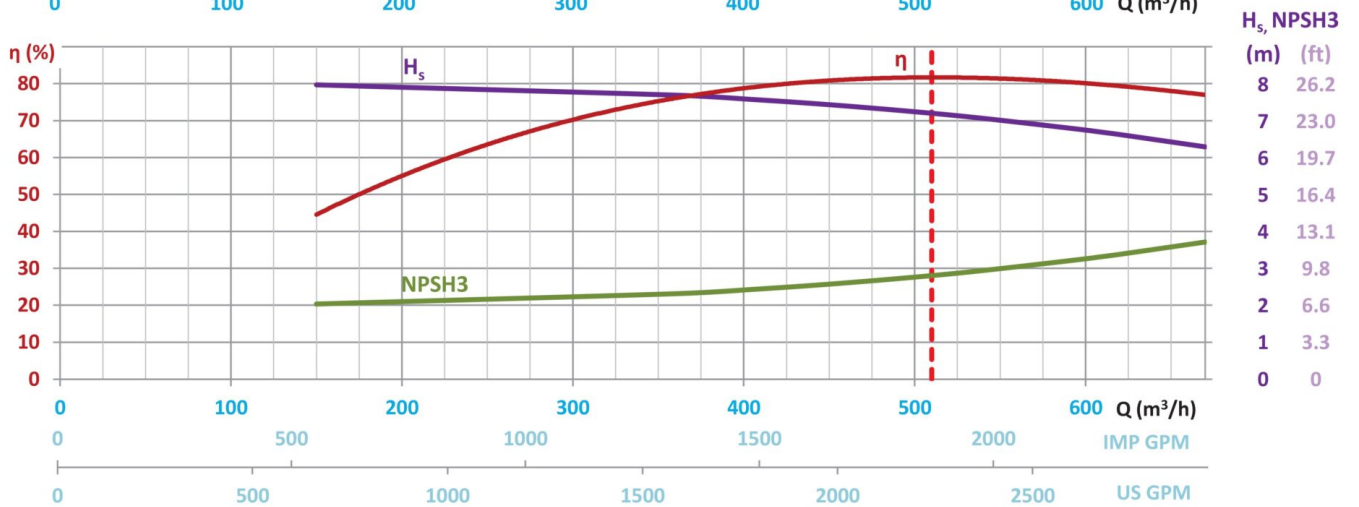
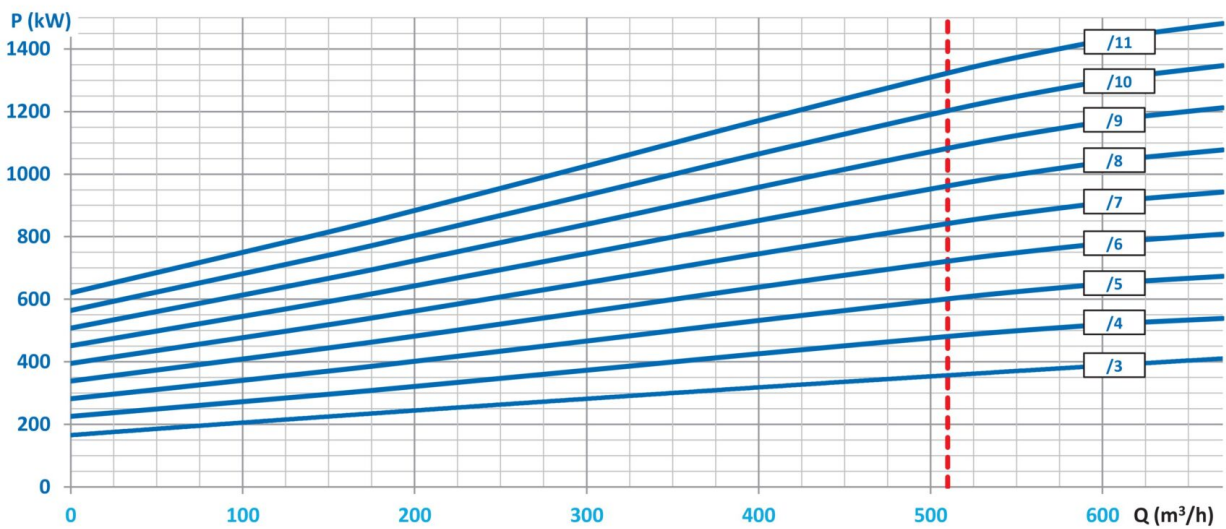
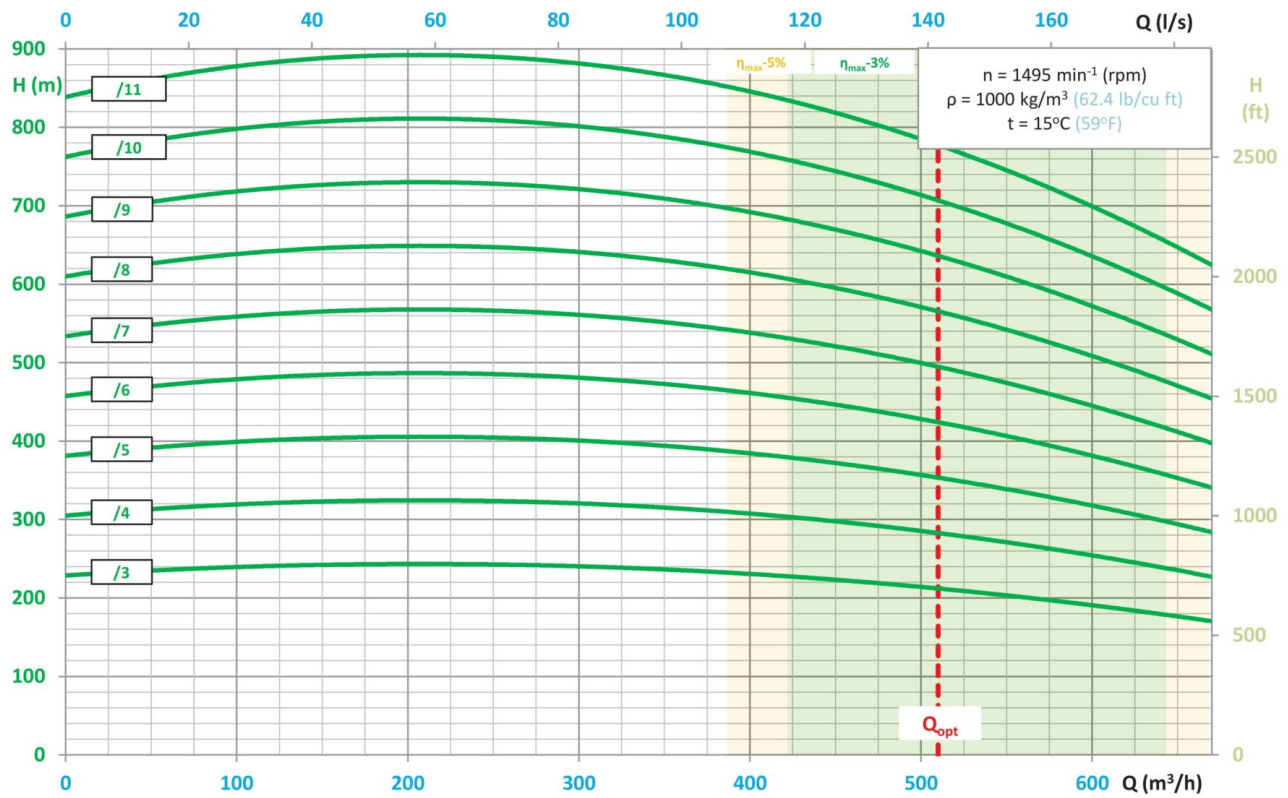

▪  $H = f(Q)$  - lift head acc. to rate flow,

- $P = f(Q)$  - power input acc. to rate flow,
- $\eta = f(Q)$  - efficiency acc. to rate of flow,
- $H_s = f(Q)$  - allowable suction head acc. to rate of flow,
- $NPSH3 = f(Q)$  - net positive suction head and rate of flow.

## MAIN DIMENSIONS OF PUMP

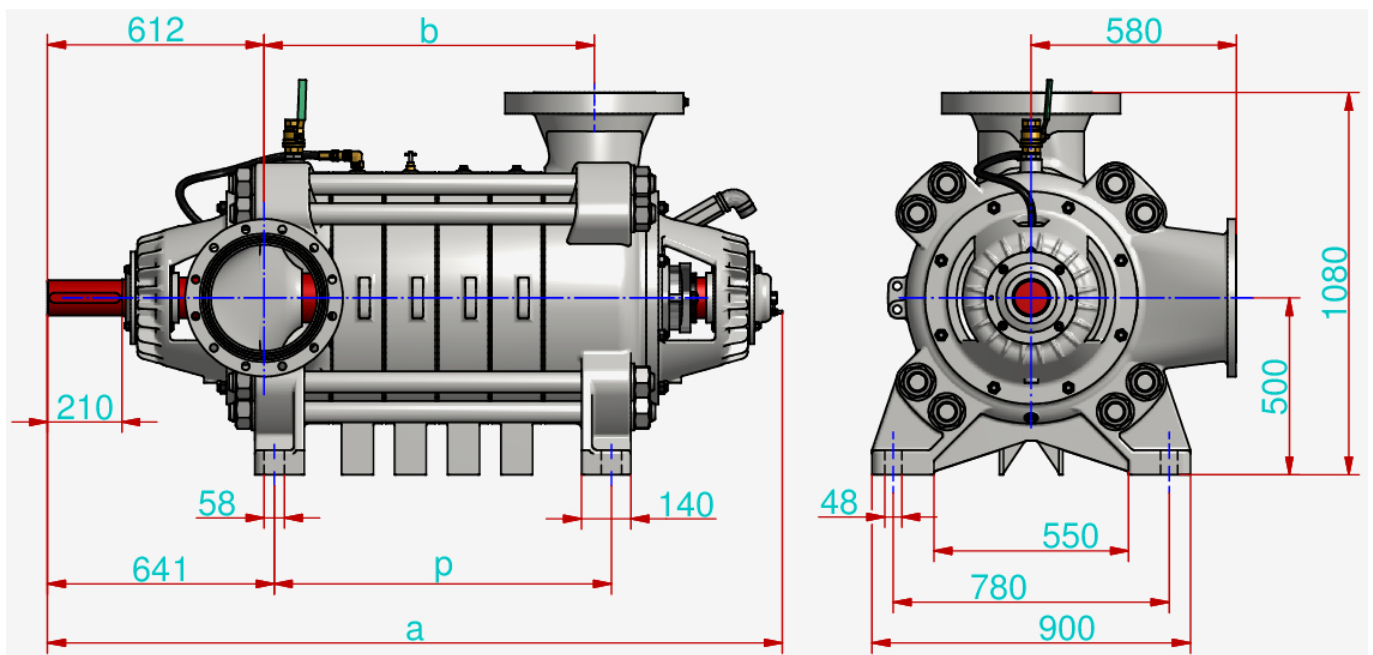

	Liczba stopni									
	3	4	5	6	7	8	9	10	11	
<b>a</b>	1770	1920	2070	2220	2370	2520	2670	2820	2970	mm
<b>b</b>	634	784	934	1084	1234	1384	1534	1684	1834	mm
<b>p</b>	653	803	953	1103	1253	1403	1553	1703	1853	mm
<b>m</b>	2150	2410	2665	2920	3180	3435	3690	3950	4210	kg

## CONNECTION SIZES OF PUMP

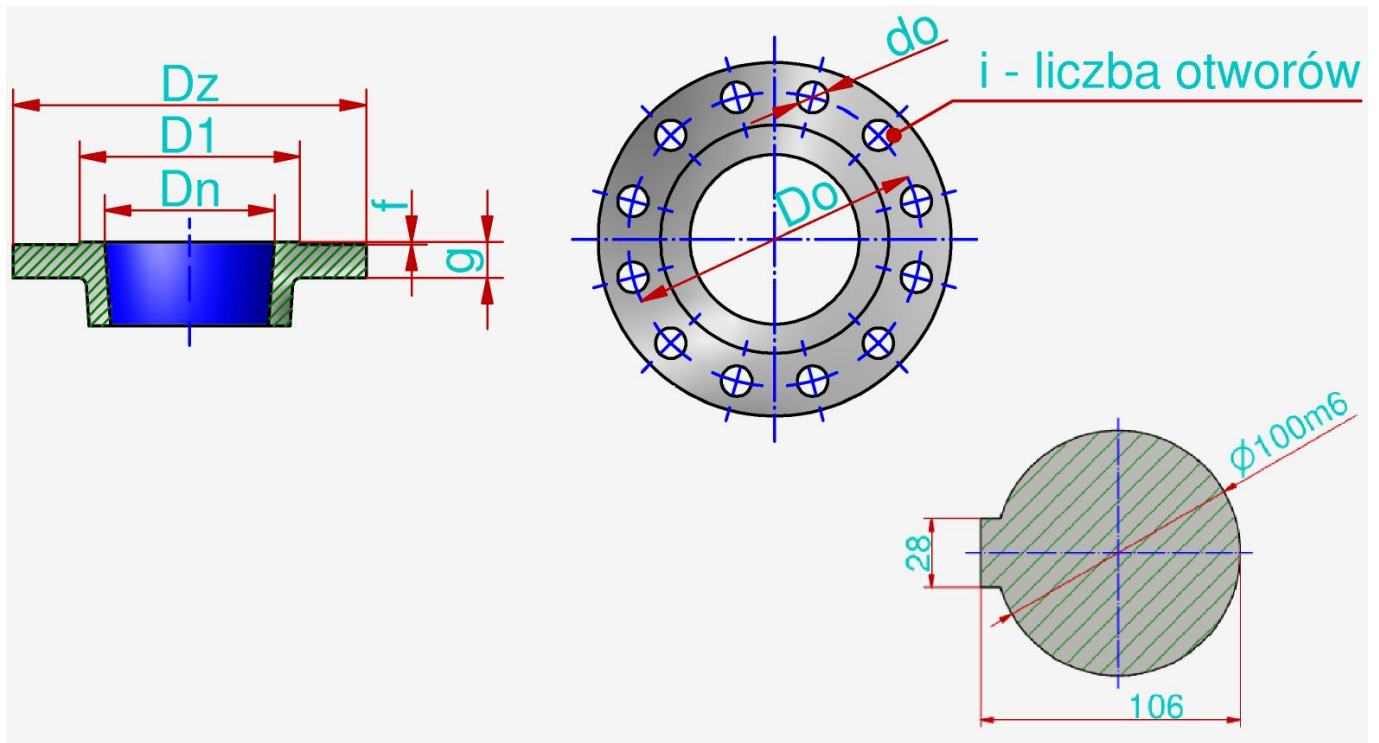

	$D_n$	$P_n$	$D_z$	$d_0$	$g$	$f$	$D_0$	$D_1$	$i$
Króciec ssawny	300	10	445	22	24	3	400	370	12
Króciec tłoczny PN100 (9-11 stopni)	250	100	505	39	60	3	430	345	12
Króciec tłoczny PN63 (6-8 stopni)	250	63	470	36	46	4	400	345	12
Króciec tłoczny PN40 (3-5 stopni)	250	40	450	33	42	4	385	345	12
	mm	bar	mm	mm	mm	mm	mm	mm	szt

The flanges are normally made in accordance with the standard PN-EN 1092-1.

**It is possible to produce pumps with parameters different than those presented in the tables and on the graphs per agreement with the manufacturer.**