

PHZ-200



DOWNLOAD



Catalog



2D



3D

SAVE TO PDF / PRINT

PUBLICATION - 2017-11-07

NOMINAL OPERATION PARAMETERS AT PURE WATER PUMPING (for the maximum rotation speed and the largest rotor)

Capacity	Q_n	500	m^3/h
Head	H	80	m
Rotational speed	n	1450*	rpm
Impeller diameter	D_z	504*	mm
Shaft power	P_n	168	kW
Weight	m	1230	kg
Max. permissible size of solids		50	mm

*Pump construction enables decreasing the operational parameters by reducing the rotation speed and/or reducing the rotor's diameter, adapting the pump to the system without choking the pump.

TYPICAL APPLICATIONS

- pumping mixtures of water and solids, with large grains and highly abrasive properties,
 - pumping mixtures of water and quartz sand, ores, coal, slag, ash,
 - mining - PHZ pumps intended to replace hydrotransport drainage pumps used so far,
 - water supply systems,
 - pressure boosting,
 - technological processes,
 - industrial systems,
 - filtration systems.
-

KEY ADVANTAGES

- long life ensured by the use of state-of-the-art corrosion and erosion resistant materials,
- possibility of operation with a frequency converter,
- possibility of serial operation,
- the pumped mixture density can reach $\rho_{\max} = 1700\text{kg/m}^3$ while pumping mixtures with a 50% content of solids in water,
- silent and smooth operation,
- connection dimensions in compliance with hydrotransport pumps,
- inflow and suction operation,
- approved for operation in explosion-hazard zones - ATEX Ex I M2.

PUMP PERFORMANCE CURVE

IN PROGRESS

MAIN DIMENSIONS OF PUMP

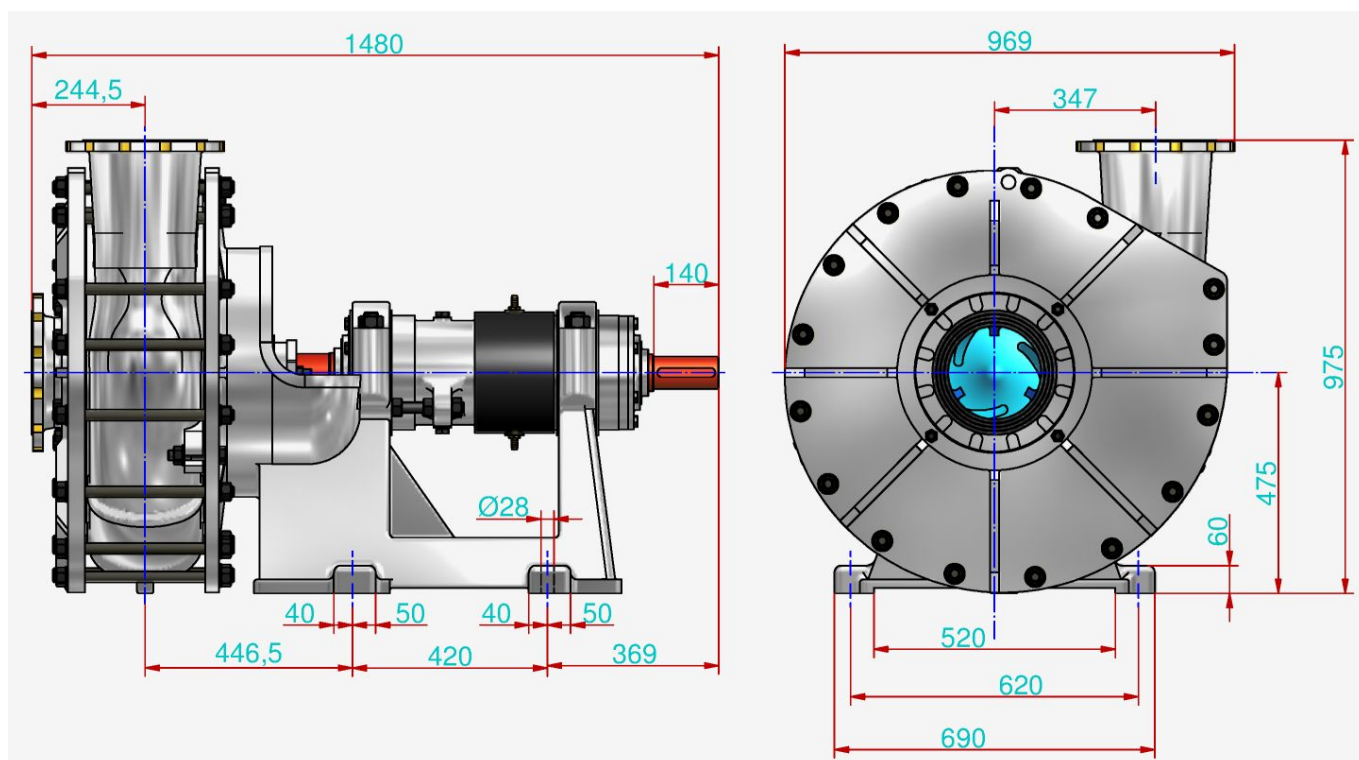

CONNECTION SIZES OF PUMP

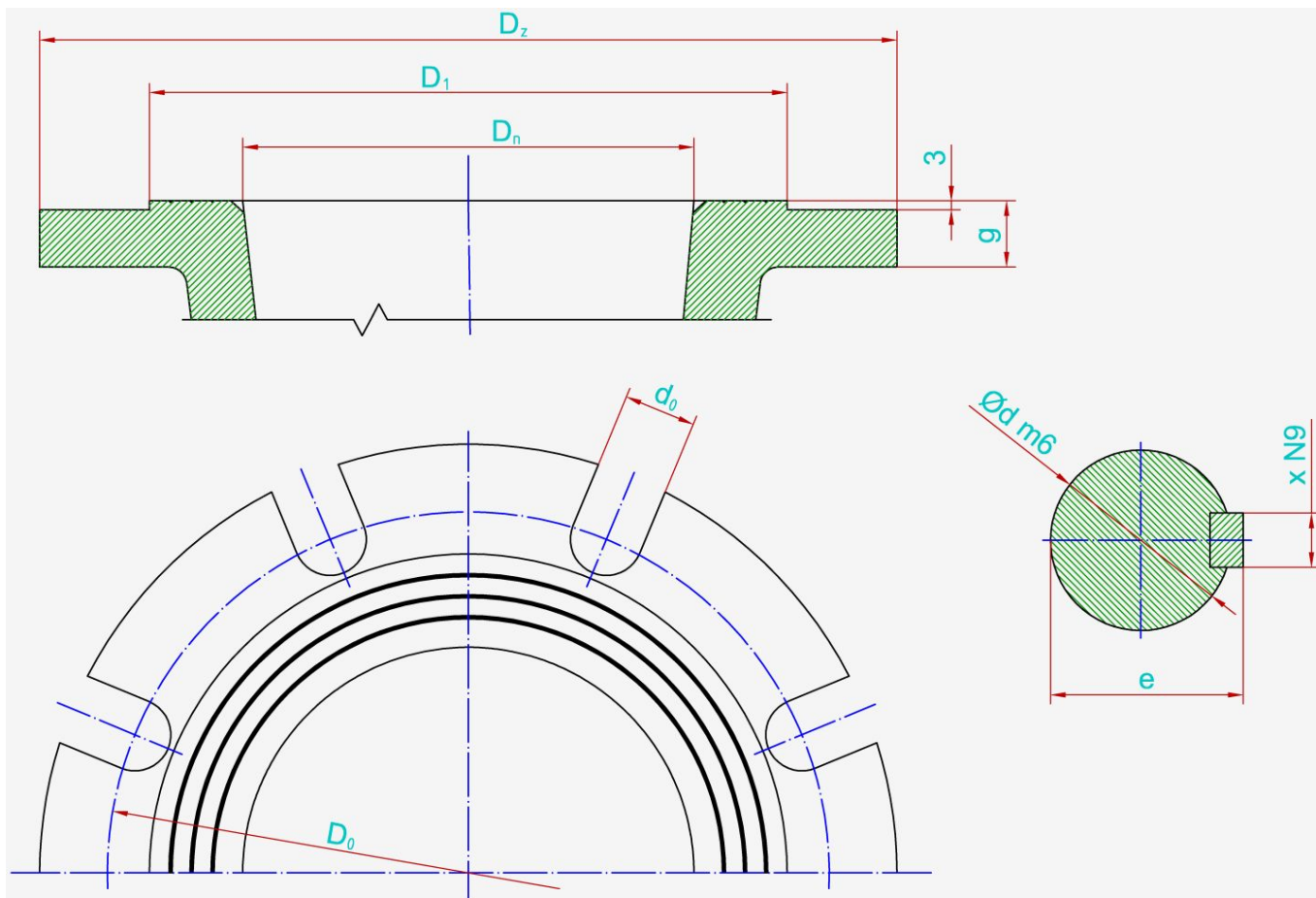

	P_n	D_n	i	D_z	d_0	g	D_0	D_1	d	e	x
Suction connector	16	200	12	340	26	24	295	268	-	-	-
Discharge connector	16	200	12	340	26	24	295	268	-	-	-
Shaft / coupling	-	-	-	-	-	-	-	-	70	74,5	20
	bar	mm	-	mm	mm	mm	mm	mm	mm	mm	mm

The flanges are normally made in accordance with the standard PN-EN 1092-1 or PN-EN 1092-2.

MAIN DIMENSIONS OF PUMP UNIT

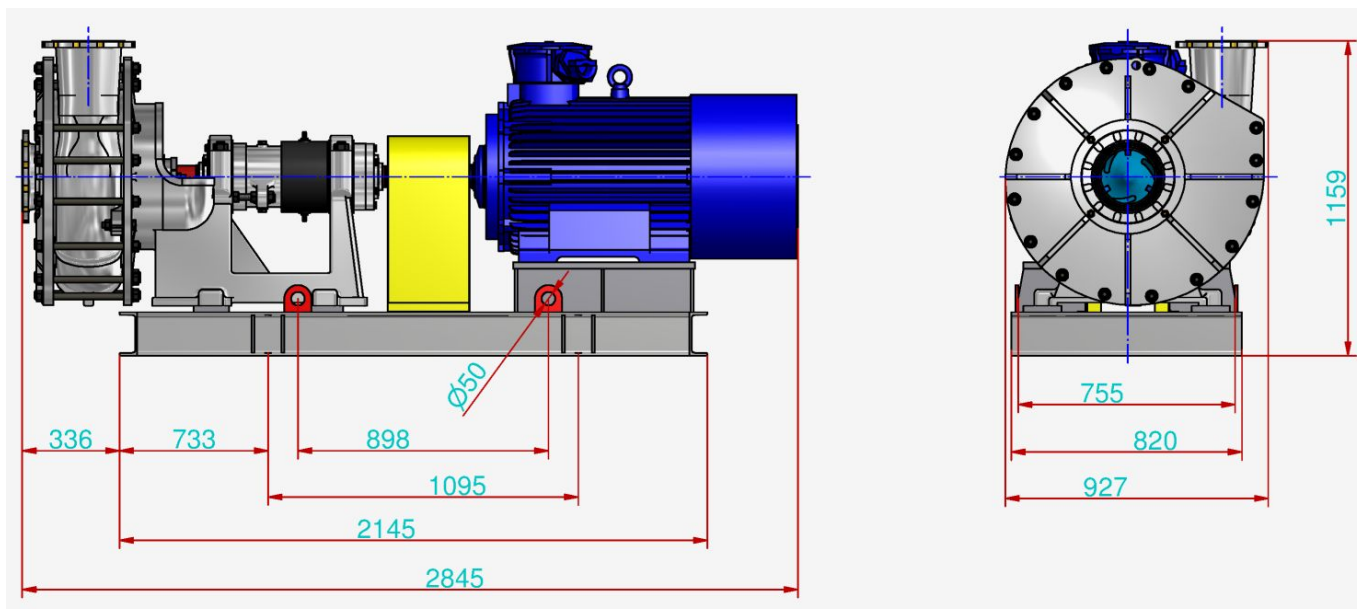

Motor type	Celma dSKg315L4	-
Coupling type	V290	-
Weight	2620	kg

It is possible to produce pumps with parameters different than those presented in the tables and on the graphs per agreement with the manufacturer.